

Programmable Frequency, Continuous Conduction Mode (CCM), Boost Power Factor Correction (PFC) Controller

Check for Samples: [UCC28180](#)

FEATURES

- 8-pin Solution (no AC line sensing needed)
- Wide Range Programmable Switching Frequency (18 kHz to 250 kHz for MOSFET and IGBT based PFC converters)
- Trimmed Current Loop Circuits for Low i_{THD}
- Reduced Current Sense Threshold (minimizes power dissipation in shunt)
- Average Current-Mode Control
- Soft Over Current and Cycle-by-Cycle Peak Current Limit Protection
- Output Over-Voltage Protection with Hysteresis Recovery
- Audible Noise Minimization Circuitry
- Open Loop Detection
- Enhance Dynamic Response During Output Over and Under-Voltage Conditions
- Maximum Duty Cycle of 96% (typical)
- Burst Mode for No Load Regulation
- VCC UVLO, Low ICC Start-Up (<75 μ A)

APPLICATIONS

- Universal AC Input, CCM Boost PFC converters in 100-W to Few-kW range
- Server and Desktop Power Supplies
- White Good Appliances (Air Conditioners, Refrigerators)
- Industrial Power Supplies (DIN Rail)
- Flat Panel TV (PDP, LCD and LED) TVs

DESCRIPTION

The UCC28180 is a flexible and easy-to-use, 8-pin, active Power Factor Correction (PFC) controller that operates under Continuous Conduction Mode (CCM) to achieve high Power Factor, low current distortion and excellent voltage regulation of boost pre-regulators in AC - DC front-ends. The controller is suitable for universal AC input systems operating in 100-W to few-kW range with the switching frequency programmable between 18 kHz to 250 kHz, to conveniently support both power MOSFET and IGBT switches. An integrated 1.5-A and 2-A (SRC-SNK) peak gate drive output, clamped internally at 15.2 V (typical), enables fast turn-on, turn-off and easy management of the external power switch without the need for buffer circuits.

Low-distortion wave shaping of the input current using average current mode control is achieved without input line sensing, reducing the external component count. In addition, the controller features reduced current sense thresholds to facilitate the use of small value shunt resistors for reduced power dissipation, especially important in high power systems. To enable low current distortion, the controller also features trimmed internal current loop regulation circuits for eliminating associated inaccuracies.

Typical Application

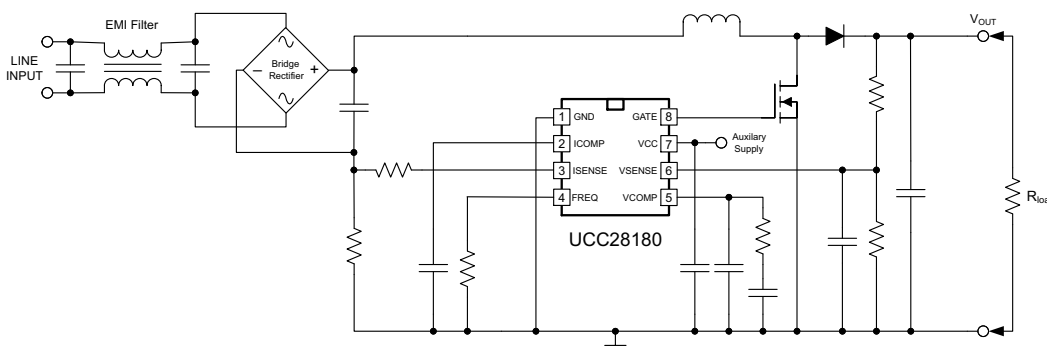

Please be aware that an important notice concerning availability, standard warranty, and use in critical applications of Texas Instruments semiconductor products and disclaimers thereto appears at the end of this data sheet.

UCC28180

SLUSBQ5A –NOVEMBER 2013–REVISED NOVEMBER 2013

www.ti.com

DESCRIPTION (CONT.)

Simple external networks allow for flexible compensation of the current and voltage control loops. In addition, UCC28180 offers an enhanced dynamic response circuit that is based on the voltage feedback signal to deliver improved response under fast load transients, both for output over-voltage and under-voltage conditions. A unique VCOMP discharge circuit provided in UCC28180 is activated whenever the voltage feedback signal exceeds V_{OVP_L} thus allowing a chance for the control loop to stabilize quickly and avoid encountering the over-voltage protection function when PWM shut-off can often cause audible noise. Controlled soft start gradually regulates the input current during start-up and reduces stress on the power switches. Numerous system-level protection features available in the controller include VCC UVLO, peak current limit, soft over-current, output open-loop detection, output over-voltage protection and open-pin detection (VISNS). A trimmed internal reference provides accurate protection thresholds and regulation set-point. The user can control low power standby mode by pulling the VSENSE pin below 0.82 V.



These devices have limited built-in ESD protection. The leads should be shorted together or the device placed in conductive foam during storage or handling to prevent electrostatic damage to the MOS gates.

ORDERING INFORMATION

PART NUMBER	PACKAGE	OPERATING TEMPERATURE RANGE, T _A
UCC28180D	SOIC 8-Pin (D) Lead (Pb)-Free/Green ⁽¹⁾ Lead (Pb)-Free/Green	-40°C to 125°C

(1) SOIC (D) package is available taped and reeled by adding "R" to the above part number. Reeled quantities are 2,500 devices per reel.

ABSOLUTE MAXIMUM RATINGS⁽¹⁾

Over operating free-air temperature range, all voltages are with respect to GND (unless otherwise noted). Currents are positive into and negative out of the specified terminal.

		VALUE		UNIT
		MIN	MAX	
Input voltage range	VCC, GATE	-0.3	22	V
	FREQ, VSENSE, VCOMP, ICOMP	-0.3	7	
Input current range	ISENSE	-24	7	
	VSENSE, ISENSE	-1	1	mA
Junction temperature, T _J	Operating	-55	150	°C
	Storage	-65	150	°C
Lead temperature, T _{SOL}	Soldering, 10 s		300	°C
Electrostatic Discharge (ESD) Protection	Human Body Model (HBM)		2	kV
	Charged Device Model (CDM)		500	V

(1) Stresses beyond those listed under "absolute maximum ratings" may cause permanent damage to the device. These are stress ratings only and functional operation of the device at these or any other condition beyond those included under "recommended operating conditions" is not implied. Exposure to absolute-maximum-rated conditions for extended periods of time may affect device reliability.

RECOMMENDED OPERATING CONDITIONS

over operating free-air temperature range (unless otherwise noted)

	MIN	MAX	UNIT
VCC input voltage from a low-impedance source	VCC _{OFF} + 1V	21	V
Operating junction temperature, T _J	-40	125	°C
Operating frequency	18	250	kHz

THERMAL INFORMATION

THERMAL METRIC ⁽¹⁾		UCC28180		UNITS
		SOIC (D)		
		8 PINS		
θ_{JA}	Junction-to-ambient thermal resistance ⁽²⁾	116.1		°C/W
θ_{JCTop}	Junction-to-case (top) thermal resistance ⁽³⁾	62.2		
θ_{JB}	Junction-to-board thermal resistance ⁽⁴⁾	56.4		
ψ_{JT}	Junction-to-top characterization parameter ⁽⁵⁾	14.4		
ψ_{JB}	Junction-to-board characterization parameter ⁽⁶⁾	55.9		
θ_{JCbott}	Junction-to-case (bottom) thermal resistance ⁽⁷⁾	N/A		

- (1) For more information about traditional and new thermal metrics, see the *IC Package Thermal Metrics* application report, [SPRA953](#).
- (2) The junction-to-ambient thermal resistance under natural convection is obtained in a simulation on a JEDEC-standard, high-K board, as specified in JESD51-7, in an environment described in JESD51-2a.
- (3) The junction-to-case (top) thermal resistance is obtained by simulating a cold plate test on the package top. No specific JEDEC-standard test exists, but a close description can be found in the ANSI SEMI standard G30-88.
- (4) The junction-to-board thermal resistance is obtained by simulating in an environment with a ring cold plate fixture to control the PCB temperature, as described in JESD51-8.
- (5) The junction-to-top characterization parameter, ψ_{JT} , estimates the junction temperature of a device in a real system and is extracted from the simulation data for obtaining θ_{JA} , using a procedure described in JESD51-2a (sections 6 and 7).
- (6) The junction-to-board characterization parameter, ψ_{JB} , estimates the junction temperature of a device in a real system and is extracted from the simulation data for obtaining θ_{JA} , using a procedure described in JESD51-2a (sections 6 and 7).
- (7) The junction-to-case (bottom) thermal resistance is obtained by simulating a cold plate test on the exposed (power) pad. No specific JEDEC standard test exists, but a close description can be found in the ANSI SEMI standard G30-88.

UCC28180

SLUSBQ5A –NOVEMBER 2013–REVISED NOVEMBER 2013

www.ti.com

ELECTRICAL CHARACTERISTICS

Unless otherwise noted, VCC=15Vdc, 0.1µF from VCC to GND, -40°C ≤ T_J = T_A ≤ +125°C. All voltages are with respect to GND. Currents are positive into and negative out of the specified terminal.

PARAMETER		TEST CONDITION	MIN	TYP	MAX	UNITS
VCC Bias Supply						
ICC _{PRESTART}	ICC Pre-start current	VCC = VCC _{OFF} - 0.2 V			75	µA
ICC _{STBY}	ICC Standby current	VSENSE = 0.5 V	1.80	2.40	2.95	mA
ICC _{ON_load}	ICC Operating current	VSENSE = 4.0 V, C _{GATE} = 4.7 nF	5.8	7.0	8.8	mA
Under Voltage LockOut (UVLO)						
VCC _{ON}	VCC Turn on threshold		10.8	11.5	12.1	V
VCC _{OFF}	VCC Turn off threshold		9.1	9.5	10.3	V
	UVLO Hysteresis		1.6	1.7	2.0	V
Variable Frequency						
f _{SW}	Minimum switching frequency	R _{FREQ} = 130 kΩ	16.3	18.0	19.8	kHz
	Typical switching frequency	R _{FREQ} = 32.7 kΩ	61.75	65.00	68.25	kHz
	Maximum switching frequency	R _{FREQ} = 8.2 kΩ	225	250	275	kHz
V _{FREQ}	Voltage at FREQ pin	T _A = 25°C	1.43	1.50	1.56	V
PWM						
D _{MIN}	Minimum duty cycle	VSENSE = 5.1 V, ISENSE = -0.25 V			0%	
D _{MAX}	Maximum duty cycle	VSENSE = 4.0 V, R _{FREQ} = 32.7 Ω	94.8%	96.5%	98.0%	
t _{OFF(min)}	Minimum off time	VSENSE = 3 V, I _{COMP} = 0.72 V	450	570	690	ns
System Protection						
V _{SOC}	ISENSE threshold, soft over current (SOC)		-0.259	-0.295	-0.312	V
V _{PCL}	ISENSE threshold, peak current limit (PCL)		-0.345	-0.4	-0.438	V
I _{ISOP}	ISENSE bias current, ISENSE open-pin protection (ISOP)	ISENSE = 0 V		-2.30	-2.95	µA
V _{ISOP}	ISENSE threshold, ISENSE open-pin protection (ISOP)	ISENSE = open pin		0.085	0.14	V
V _{OLP}	VSENSE threshold, open loop protection (OLP)	ICOMP = 1 V, ISENSE = 0 V	15.6	16.5	17.6	%V _{REF}
	Open loop protection (OLP) Internal pull-down current	VSENSE = 0.5 V		100	325	nA
V _{UVD}	VSENSE threshold, output under-voltage detection (UVD) used for enhanced dynamic response ⁽¹⁾		93.25	95.00	97.00	%V _{REF}
V _{OVD}	VSENSE threshold, output over-voltage detection (OVD) used for Enhanced dynamic response ⁽¹⁾		103.00	105.00	106.75	%V _{REF}
V _{OVP_L}	Output over-voltage protection low threshold, VCOMP is discharged by a 4kΩ resistor when VSENSE > V _{OVP_L}		105	107	109	%V _{REF}
V _{OVP_H}	Output over-voltage protection high threshold, PWM shuts off when VSENSE > V _{OVP_H}		107	109	111	%V _{REF}
V _{OVP_H(RST)}	Output over-voltage protection (VOVP_H) reset threshold, PWM turns on when VSENSE < V _{OVP_H(RST)}		100	102	104	%V _{REF}
	ICOMP threshold, external overload protection			0.20	0.25	%V _{REF}
Current Loop						
g _{mi}	Transconductance gain		0.75	0.95	1.10	mS
	Output linear range ⁽¹⁾			±50		µA
	ICOMP voltage during OLP	VSENSE = 0 V	2.7	3.0	3.3	V

(1) Not production tested. Characterized by design

ELECTRICAL CHARACTERISTICS (continued)

Unless otherwise noted, VCC=15Vdc, 0.1μF from VCC to GND, $-40^{\circ}\text{C} \leq T_J = T_A \leq +125^{\circ}\text{C}$. All voltages are with respect to GND. Currents are positive into and negative out of the specified terminal.

PARAMETER		TEST CONDITION	MIN	TYP	MAX	UNITS
Voltage Loop						
V _{REF}	Reference voltage	T _A = 25°C	4.93	5.00	5.07	V
		-40°C ≤ T _A ≤ +125°C	4.87	5.00	5.15	V
g _{mv}	Transconductance gain without EDR		-40	-56	-70	μS
g _{mv-EDR}	Transconductance gain under EDR		-230	-280	-340	μS
	Maximum sink current under normal operation	VSENSE = 5 V, VCOMP = 4 V	23	40	57	μA
	Source current under soft start	VSENSE = 4 V, VCOMP = 4 V	-29	-40	-52	μA
	Maximum current under EDR operation	VSENSE = 4 V, VCOMP = 2.5 V	-200	-241		μA
	VSENSE input bias current	VSENSE = 5 V	20	100	250	nA
	VCOMP voltage during OLP	VSENSE = 0.5 V, I _{VCOMP} = 0.5 mA	0.00	0.04	0.10	V
	VCOMP rapid discharge current	VCOMP = 2 V, VCC = floating		0.37		mA
V _{PRECHARGE}	VCOMP precharge voltage	I _{VCOMP} = -100 μA, VSENSE = 4 V		1.5		V
I _{PRECHARGE}	VCOMP precharge current	VCOMP = 0 V		-1		mA
	VSENSE threshold, end-of-soft-start	Initial Start-up		98		%V _{REF}
Gate Driver						
	GATE current, peak, sinking ⁽²⁾	C _{GATE} = 4.7 nF		2.0		A
	GATE current, peak, sourcing ⁽²⁾	C _{GATE} = 4.7 nF		-1.5		A
	GATE rise time	C _{GATE} = 4.7 nF, GATE = 2 V to 8 V	8	40	60	ns
	GATE fall time	C _{GATE} = 4.7 nF, GATE = 8 V to 2 V	8	25	40	ns
	GATE low voltage, no load	I _{GATE} = 0 A		0.00	0.01	V
	GATE low voltage, sinking	I _{GATE} = 20 mA		0.04	0.06	V
	GATE low voltage, sourcing	I _{GATE} = -20 mA		-0.04	-0.06	V
	GATE low voltage, sinking, OFF	VCC = 5 V, I _{GATE} = 5 mA	0.10	0.20	0.31	V
	GATE low voltage, sinking, OFF	VCC = 5 V, I _{GATE} = 20 mA	0.4	0.8	1.4	V
	GATE high voltage	VCC = 20 V, C _{GATE} = 4.7 nF	14.5	15.2	16.1	V
	GATE high voltage	VCC = 12.2 V, C _{GATE} = 4.7 nF	10.8	11.2	12	V
	GATE high voltage	VCC = VCC _{OFF} + 0.2 V, C _{GATE} = 4.7 nF	8.2	9.0	10.1	V

(2) Not production tested. Characterized by design

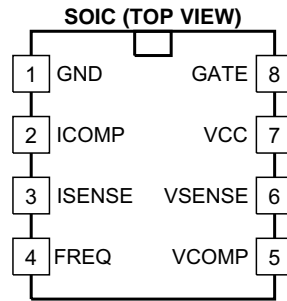
DEVICE INFORMATION

PIN FUNCTIONS

NAME	I/O	PIN #	FUNCTION
GATE	O	8	Gate Drive: Integrated push-pull gate driver for one or more external power MOSFETs. Typical 2.0-A sink and 1.5-A source capability. Output voltage is typically clamped at 15.2 V (typical).
GND		1	Ground: device ground reference.
ICOMP	O	2	Current Loop Compensation: Transconductance current amplifier output. A capacitor connected to GND provides compensation and averaging of the current sense signal in the current control loop. The controller is disabled if the voltage on ICOMP is less than 0.2 V, (ICOMPP protection function).
ISENSE	I	3	Inductor Current Sense: Input for the voltage across the external current sense resistor, which represents the instantaneous current through the PFC boost inductor. This voltage is averaged by the current amplifier to eliminate the effects of ripple and noise. <i>Soft Over Current (SOC)</i> limits the average inductor current. <i>Cycle-by-cycle peak current limit (PCL)</i> immediately shuts off the GATE drive if the peak-limit voltage is exceeded. An internal 2.3- μ A current source pulls ISENSE above 0.085 V to shut down PFC operation if this pin becomes open-circuited, (ISOP protection function). Use a 220- Ω resistor between this pin and the current sense resistor to limit inrush-surge currents into this pin.
VCC		7	Device Supply: External bias supply input. <i>Under-Voltage Lockout (UVLO)</i> disables the controller until VCC exceeds a turn-on threshold of 11.5 V. Operation continues until VCC falls below the turn-off (UVLO) threshold of 9.5 V. A ceramic by-pass capacitor of 0.1 μ F minimum value should be connected from VCC to GND as close to the device as possible for high-frequency filtering of the VCC voltage.
VCOMP	O	5	Voltage Loop Compensation: Transconductance voltage error amplifier output. A resistor-capacitor network connected from this pin to GND provides compensation. VCOMP is held at GND until VCC, and VSENSE exceed their threshold voltages. Once these conditions are satisfied, VCOMP is charged until the VSENSE voltage reaches its nominal regulation level. When Enhanced Dynamic Response (EDR) is engaged, a higher transconductance is applied to VCOMP to reduce the charge or discharge time for faster transient response. <i>Soft Start</i> is programmed by the capacitance on this pin. VCOMP is pulled low when VCC UVLO, OLP/Standby, ICOMPP and ISOP functions are activated.
FREQ	O	4	Switching Frequency Setting: This pin allows the setting of the operating switching frequency by connecting a resistor to ground. The programmable frequency range is from 18 kHz to 250 kHz.
VSENSE	I	6	Output Voltage Sense: An external resistor-divider network connected from this pin to the PFC output voltage provides feedback sensing for regulation to the internal 5-V reference voltage. A small capacitor from this pin to GND filters high-frequency noise. Standby disables the controller and discharges VCOMP when the voltage at VSENSE drops below the Open-Loop Protection (OLP) threshold of 16.5% V_{REF} (0.82 V). An internal 100-nA current source pulls VSENSE to GND during pin disconnection. <i>Enhanced Dynamic Response (EDR)</i> rapidly returns the output voltage to its normal regulation level when a system line or load step causes VSENSE to rise above 105% or fall below 95% of the reference voltage. Two level <i>Output Over-Voltage Protection (OVP)</i> : a 4-k Ω resistor connects VCOMP to ground to rapidly discharge VCOMP when VSENSE exceeds 107% (V_{OVP_L}) of the reference voltage. If VSENSE exceeds 109% (V_{OVP_H}) of the reference voltage, GATE output will be disabled until VSENSE drops below 102% of the reference voltage.

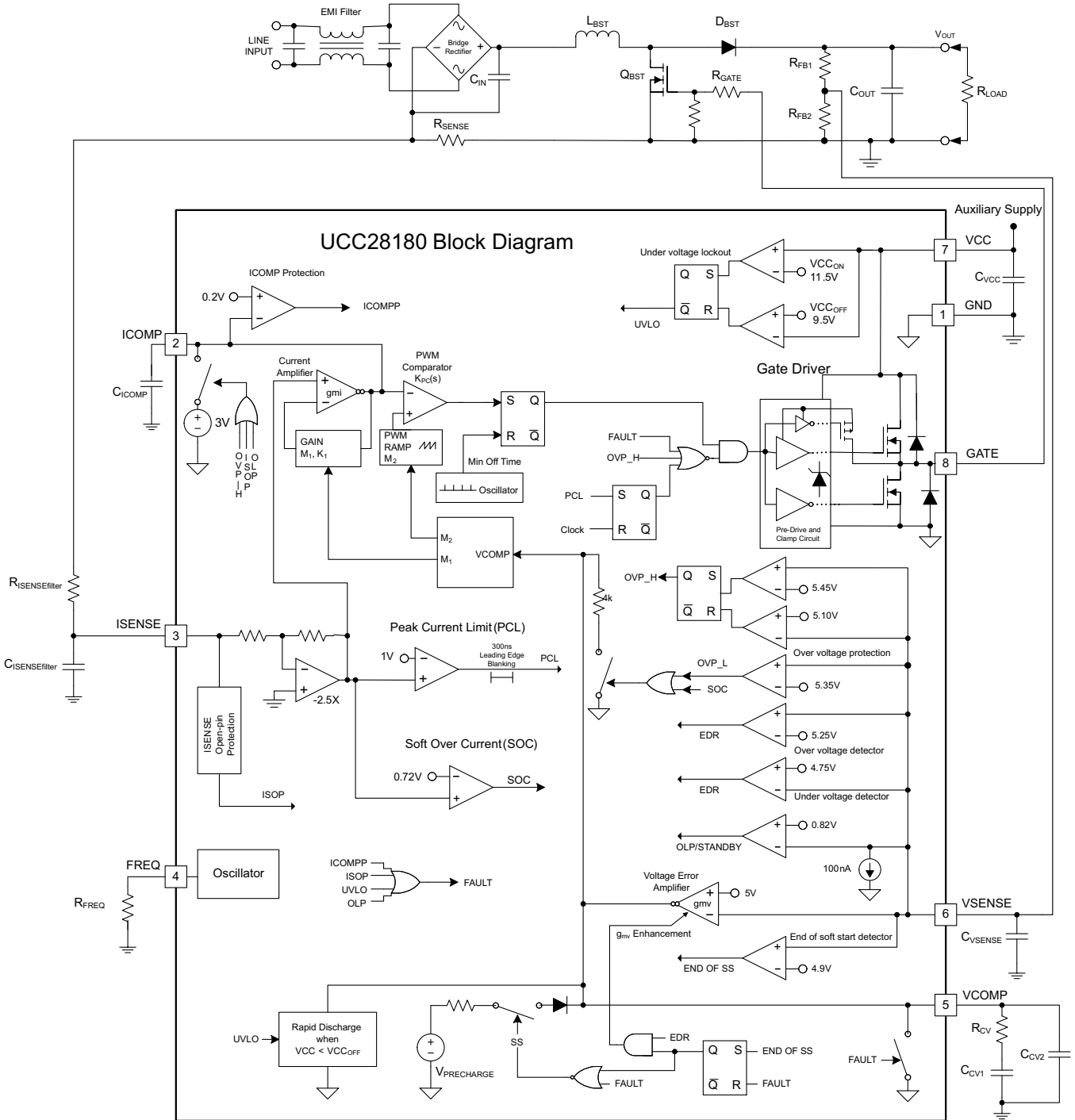
BLOCK DIAGRAM



TYPICAL CHARACTERISTICS

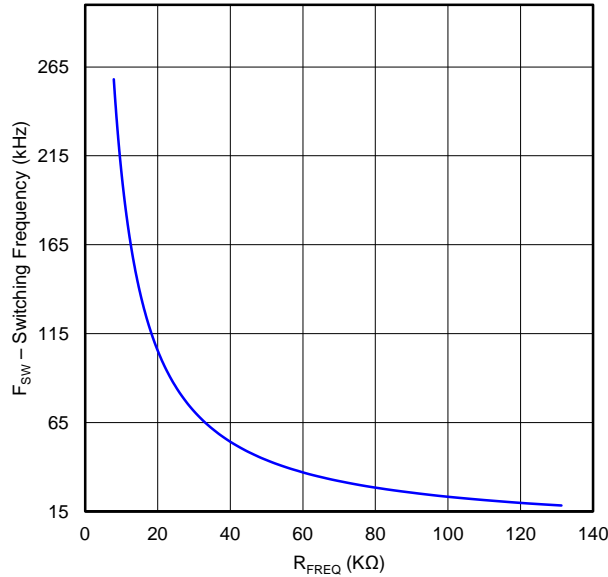

Figure 1. Switching Frequency vs. Resistor

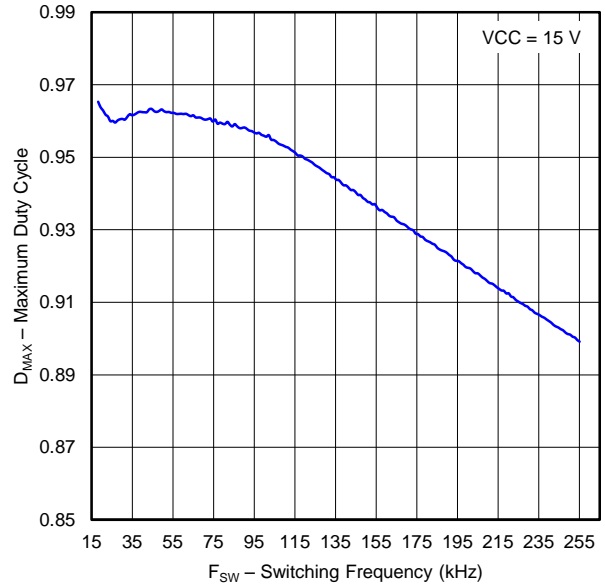

Figure 2. Maximum Duty Cycle vs. Switching Frequency

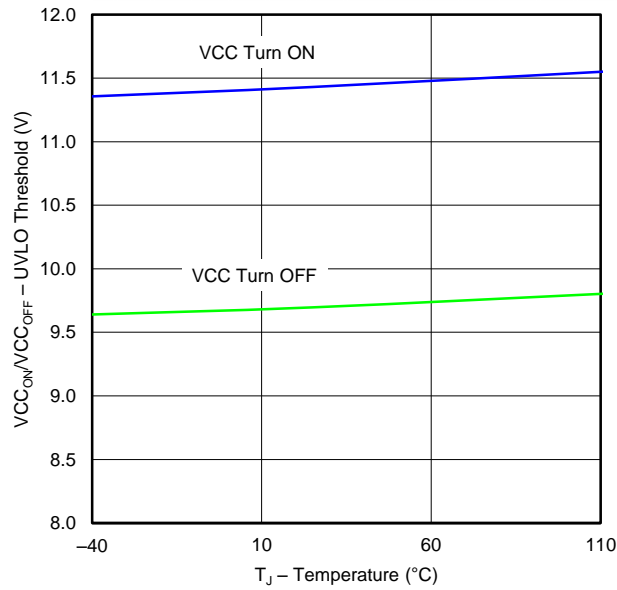

Figure 3. UVLO Threshold vs. Temperature

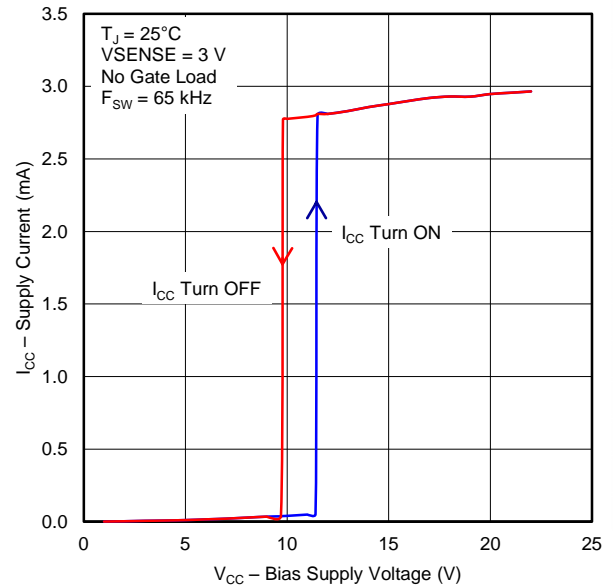

Figure 4. Supply Current vs. Bias Supply Voltage

TYPICAL CHARACTERISTICS (continued)

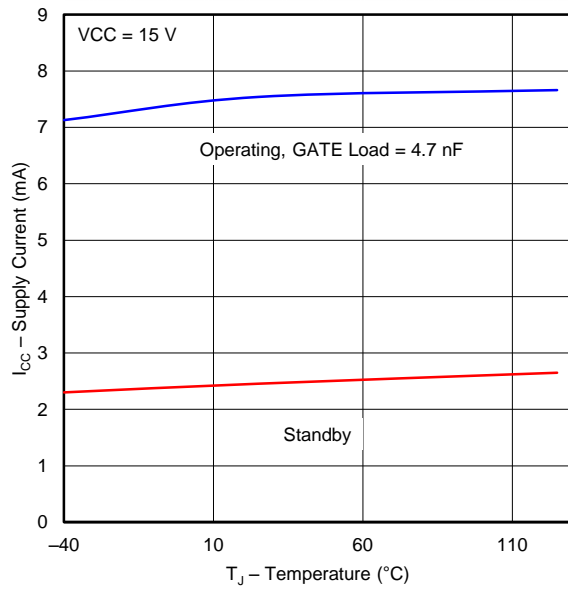

Figure 5. Supply Current vs. Temperature

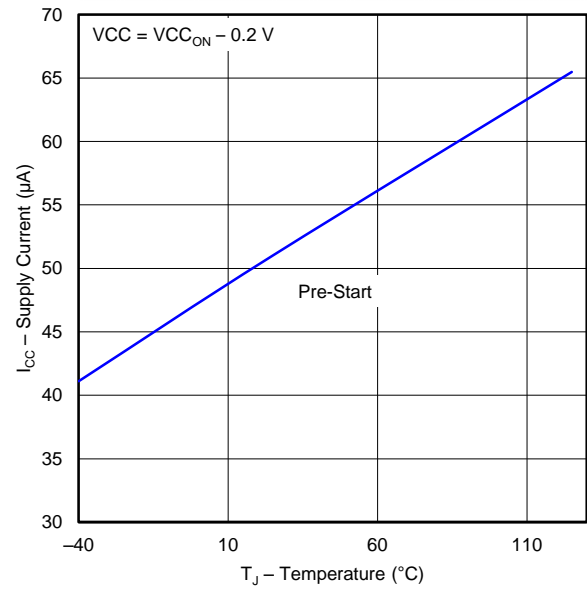

Figure 6. Pre-Start Supply Current vs. Temperature

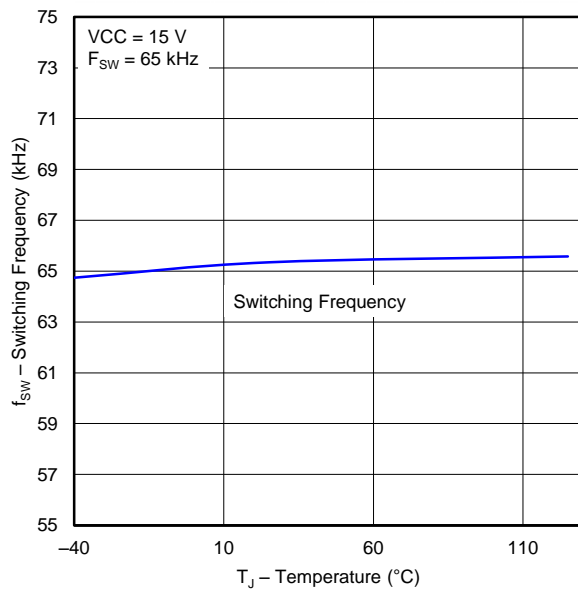

Figure 7. Oscillator Frequency (65 kHz) vs. Temperature

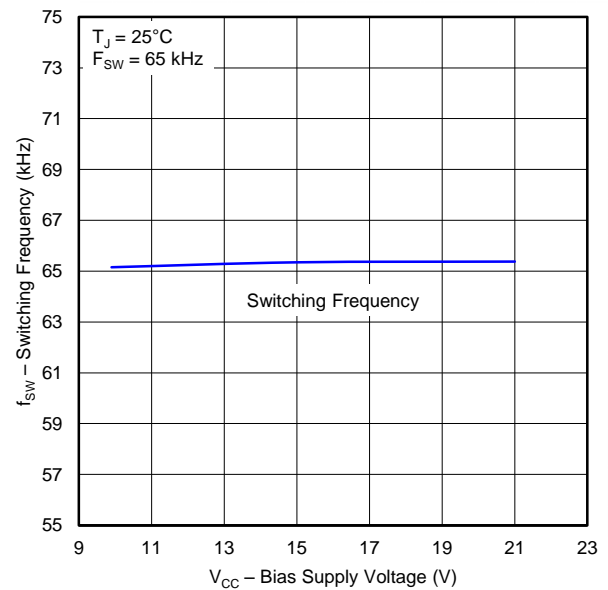

Figure 8. Oscillator Frequency (65 kHz) vs. Bias Supply Voltage

TYPICAL CHARACTERISTICS (continued)

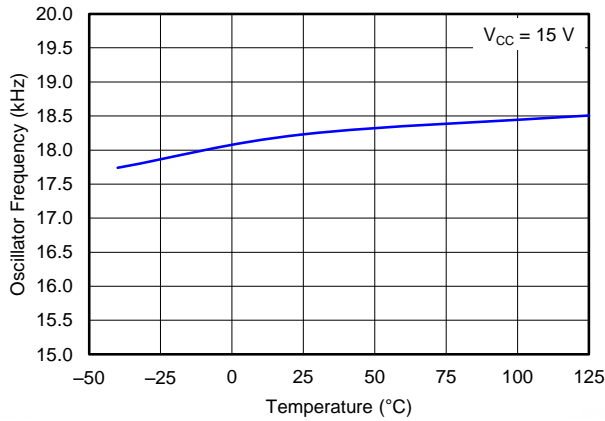

Figure 9. Oscillator Frequency (18 kHz) vs. Temperature

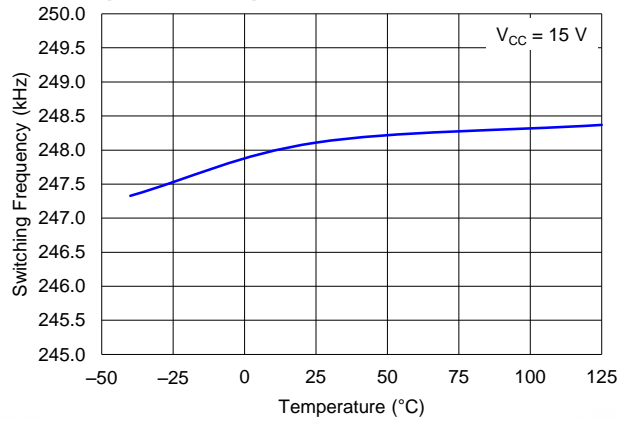

Figure 10. Oscillator Frequency (250 kHz) vs. Temperature

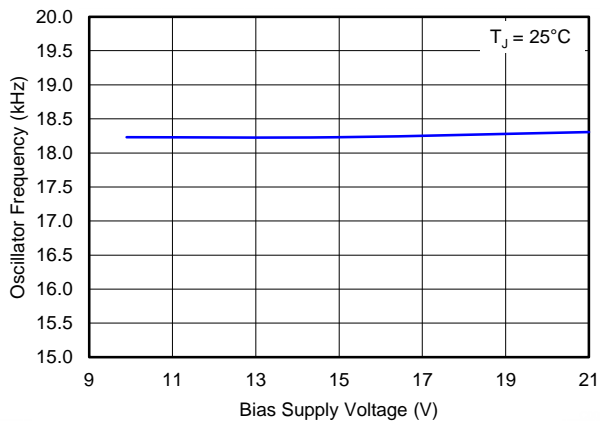

Figure 11. Oscillator Frequency (18 kHz) vs. Bias Voltage

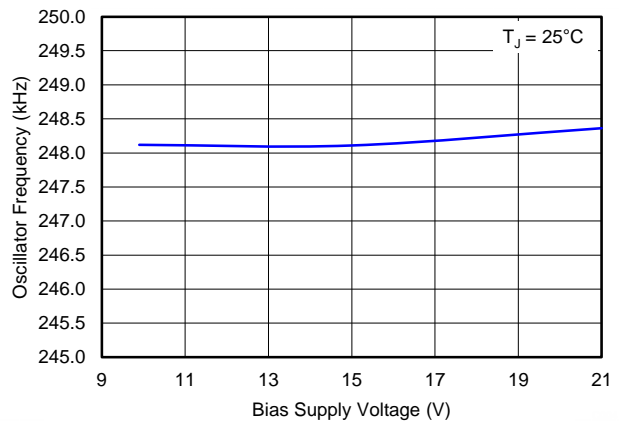

Figure 12. Oscillator Frequency (250 kHz) vs. Bias Voltage

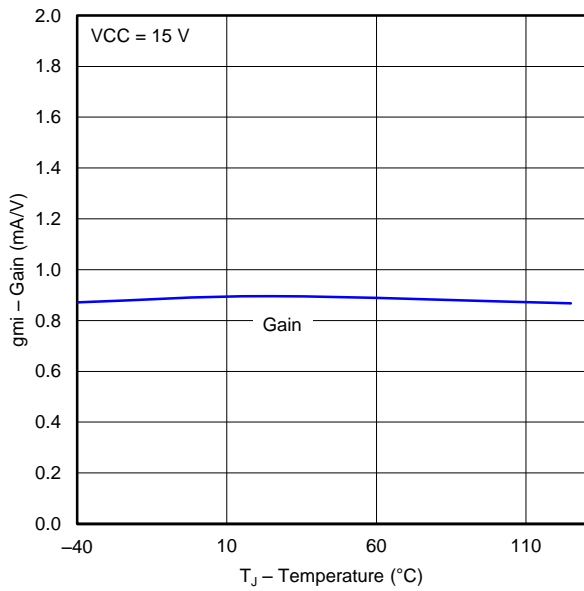

Figure 13. Current Loop Gain vs. Temperature

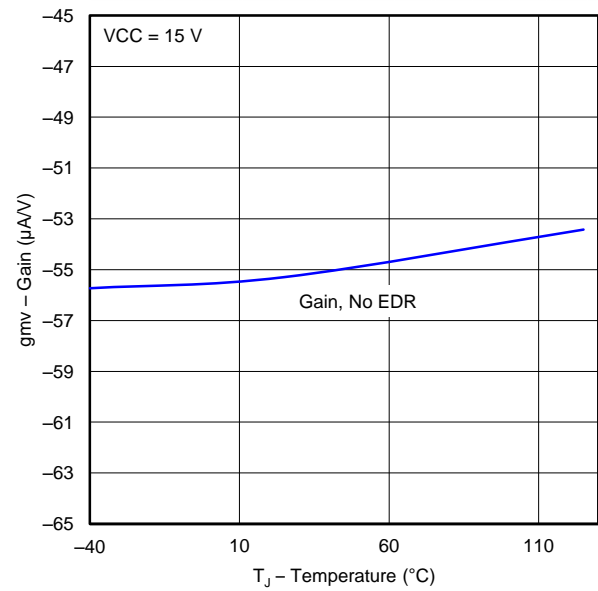

Figure 14. Voltage Loop Gain vs. Temperature

TYPICAL CHARACTERISTICS (continued)

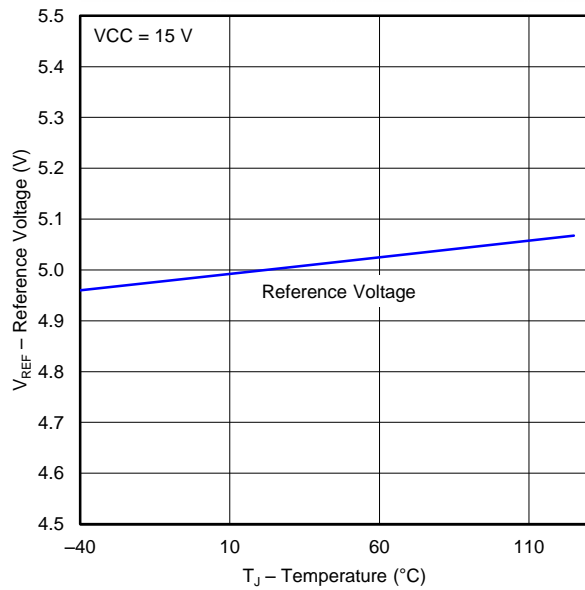

Figure 15. Reference Voltage vs. Temperature

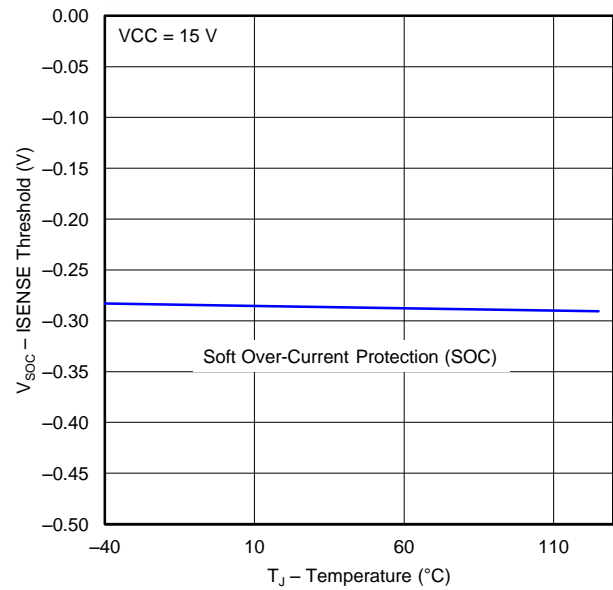

Figure 16. I_{SENSE} Threshold Soft Over Current (SOC) vs. Temperature

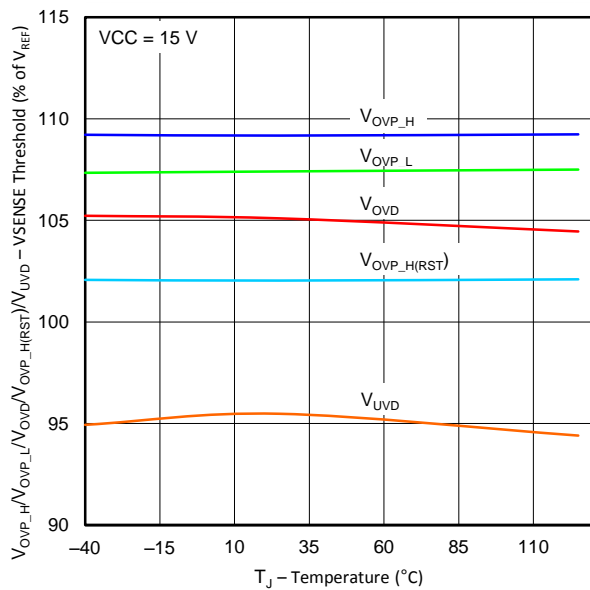

Figure 17. V_{SENSE} Threshold vs. Temperature

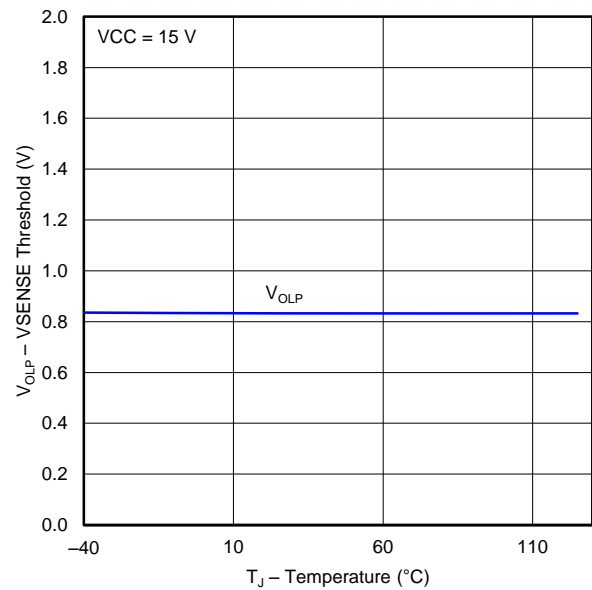

Figure 18. V_{SENSE} Threshold Open Loop vs. Temperature

TYPICAL CHARACTERISTICS (continued)

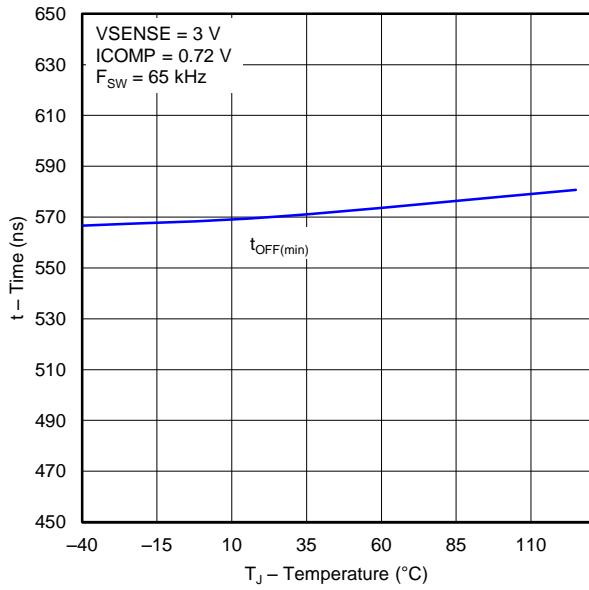

Figure 19. Minimum Off Time vs. Temperature

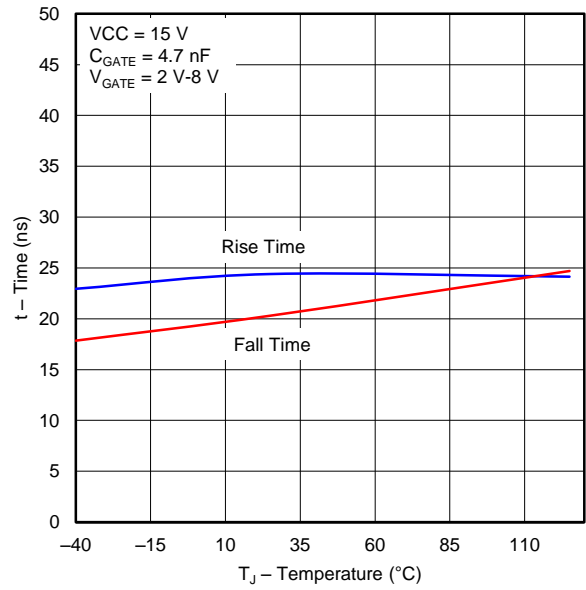

Figure 20. Gate Drive Rise/Fall Time vs. Temperature

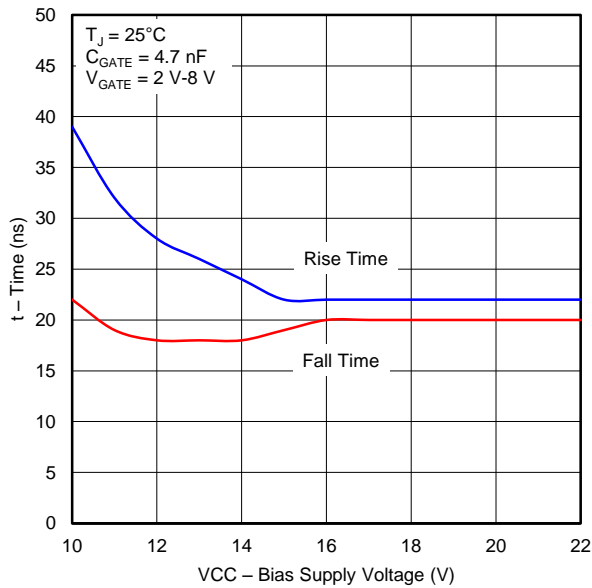

Figure 21. Gate Drive Rise/Fall Time vs. Bias Supply Voltage

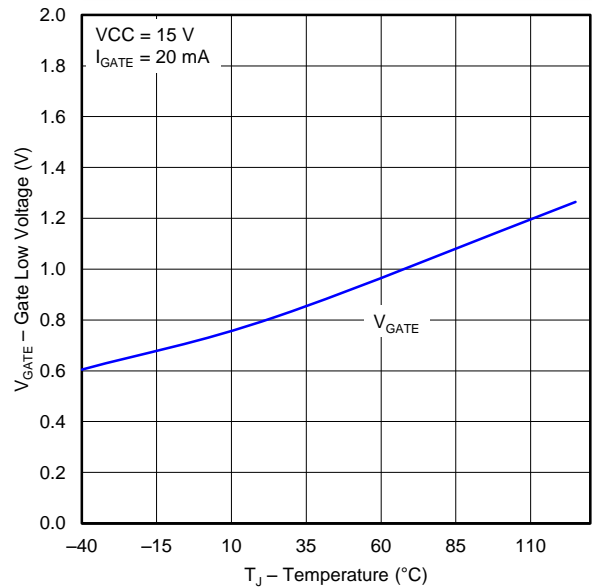

Figure 22. Gate Low Voltage vs. Temperature

APPLICATION INFORMATION

UCC28180 Operation

The UCC28180 is a switch-mode controller used in boost converters for power factor correction operating at a fixed frequency in continuous conduction mode. The UCC28180 requires few external components to operate as an active PFC pre-regulator. The operating switching frequency can be programmed from 18 kHz to 250 kHz simply by connecting the **FREQ** pin to ground through a resistor.

The internal 5-V reference voltage provides for accurate output voltage regulation over the typical world-wide 85-VAC to 265-VAC mains input range from zero to full output load. The usable system load ranges from 100 W to few kW.

Regulation is accomplished in two loops. The inner current loop shapes the average input current to match the sinusoidal input voltage under continuous inductor current conditions. Under light-load conditions, depending on the boost inductor value, the inductor current may go discontinuous but still meet Class-A/D requirements of IEC 61000-3-2 despite the higher harmonics. The outer voltage loop regulates the PFC output voltage by generating a voltage on **VCOMP** (dependent upon the line and load conditions) which determines the internal gain parameters for maintaining a low-distortion, steady-state, input-current wave shape.

Bias Supply

The UCC28180 operates from an external bias supply. It is recommended that the device be powered from a regulated auxiliary supply. (This device is not intended to be used from a *bootstrap* bias supply. A *bootstrap* bias supply is fed from the input high voltage through a resistor with sufficient capacitance on **VCC** to hold up the voltage on **VCC** until current can be supplied from a bias winding on the boost inductor. For that reason, the minimal hysteresis on **VCC** would require an unreasonable value of hold-up capacitance.)

During normal operation, when the output is regulated, current drawn by the device includes the nominal run current plus the current supplied to the gate of the external boost switch. Decoupling of the bias supply must take switching current into account in order to keep ripple voltage on **VCC** to a minimum. A ceramic capacitor of 0.1- μ F minimum value from **VCC** to **GND** with short, wide traces is recommended.

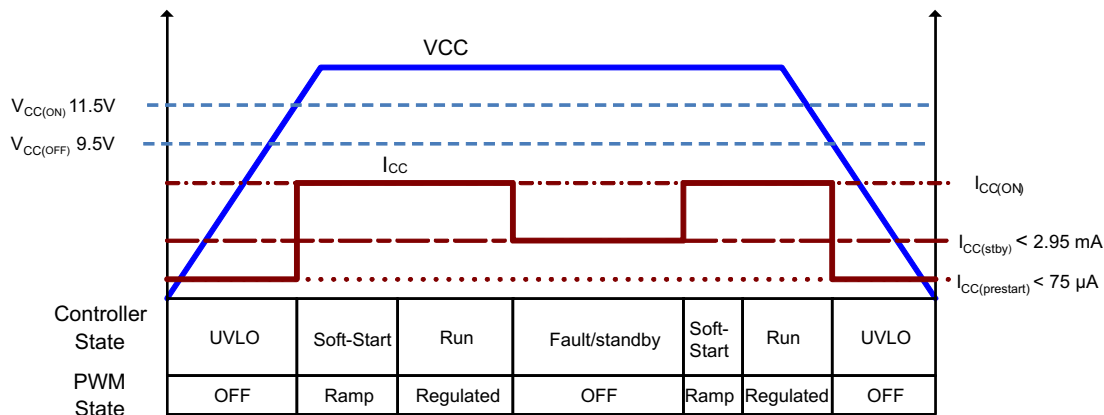

Figure 23. Device Supply States

The device's bias operates in several states. During startup, **VCC** Under-Voltage LockOut (**UVLO**) sets the minimum operational DC input voltage of the controller. There are two **UVLO** thresholds. When the **UVLO** turn-on threshold is exceeded, the PFC controller turns ON. If the **VCC** voltage falls below the **UVLO** turn-off threshold, the PFC controller turns off. During **UVLO**, current drawn by the device is minimal. After the device turns on, **Soft Start (SS)** is initiated and the boost inductor current is ramped up in a controlled manner to reduce the stress on the external components and avoids output voltage overshoot. During soft start and after the output is in regulation, the device draws its normal run current. If any of several fault conditions are encountered or if the device is put in standby with an external signal, the device draws a reduced standby current.

Soft Start

Soft-Start controls the rate of rise of VCOMP in order to obtain a linear control of the increasing duty cycle as a function of time. VCOMP, the output of the voltage loop transconductance amplifier, is pulled low during UVLO, ICOMPP, ISOP and OLP (Open-Loop Protection)/STANDBY. Once the fault condition is released, an initial pre-charge source rapidly charges VCOMP to 1.5 V. After that point, a constant 40 μ A of current is sourced into the compensation components causing the voltage on this pin to ramp linearly until the output voltage reaches 85% of its final value. At this point, the sourcing current decreases until the output voltage reaches its final rated voltage. The soft-start time is controlled by the voltage error amplifier compensation capacitor values selected, and is user programmable based on desired loop crossover frequency. Once the output voltage exceeds 98% of rated voltage, soft start is over, the initial pre-charge source is disconnected, and EDR is no longer inhibited.

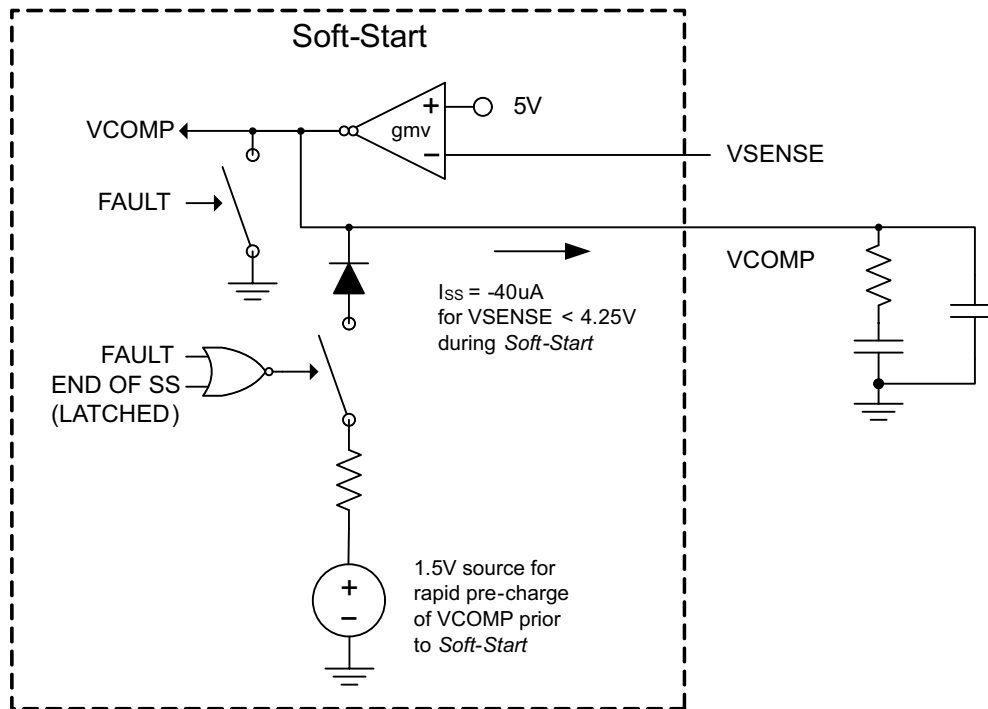

Figure 24. Soft Start

System Protection

System-level protection features help keep the system within safe operating limits.

VCC Under-Voltage LockOut (UVLO)

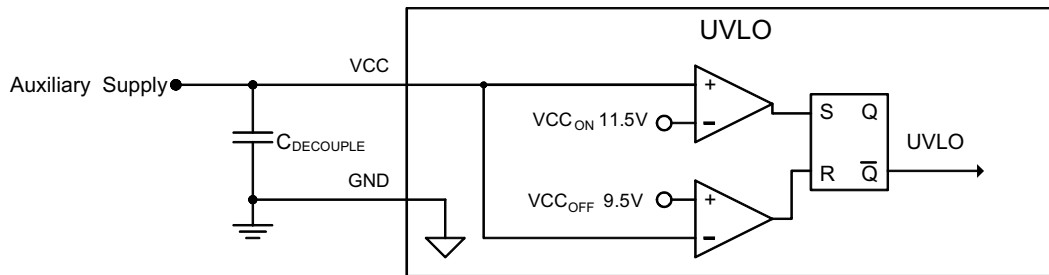

Figure 25. UVLO

During startup, Under-Voltage LockOut (UVLO) keeps the device in the off state until VCC rises above the 11.5-V enable threshold, $V_{CC_{ON}}$. With a typical 1.7 V of hysteresis on UVLO to increase noise immunity, the device turns off when VCC drops to the 9.5-V disable threshold, $V_{CC_{OFF}}$.

If, during a brief AC-line dropout, the VCC voltage falls below the level necessary to bias the internal FAULT circuitry, the UVLO condition enables a special rapid discharge circuit which continues to discharge the VCOMP capacitors through a low impedance despite a complete lack of VCC. This helps to avoid an excessive current surge should the AC-line return while there is still substantial voltage stored on the VCOMP capacitors. Typically, these capacitors can be discharged to less than 1 V within 150 ms of loss of VCC.

Output Over-Voltage Protection (OVP)

There are two levels of OVP: When VSENSE exceeds 107% (V_{OVP_L}) of the reference voltage, a 4-k Ω resistor connects VCOMP to ground to rapidly discharge VCOMP. If VSENSE exceeds 109% (V_{OVP_H}) of the reference voltage, GATE output is disabled until VSENSE drops below 102% of the reference voltage.

Open Loop Protection/Standby (OLP/Standby)

If the output voltage feedback components were to fail and disconnect (open loop) the signal from the VSENSE input, then it is likely that the voltage error amp would increase the GATE output to maximum duty cycle. To prevent this, an internal pull-down forces VSENSE low. If the output voltage falls below 16.5% of its rated voltage, causing VSENSE to fall below 0.82 V, the device is put in standby, a state where the PWM switching is halted and the device is still on but draws standby current below 2.95 mA. This shutdown feature also gives the designer the option of pulling VSENSE low with an external switch (standby function).

ISENSE Open-Pin Protection (ISOP)

If the current feedback components were to fail and disconnect (open loop) the signal to the ISENSE input, then it is likely that the PWM stage would increase the GATE output to maximum duty cycle. To prevent this, an internal pull-up source drives ISENSE above 0.085 V so that a detector forces a state where the PWM switching is halted and the device is still on but draws standby current below 2.95 mA. This shutdown feature avoids continual operation in OVP and severely distorted input current.

ICOMP Open-Pin Protection (ICOMPP)

If the ICOMP pin shorts to ground, then the GATE output increases to maximum duty cycle. To prevent this, once ICOMP pin voltage falls below 0.2 V, the PWM switching is halted and the device is still on but draws standby current below 2.95 mA.

FAULT Protection

VCC UVLO, OLP/Standby, ISOP and ICOMPP functions constitute the fault protection feature in the UCC28180. Under fault protection, VCOMP pin is pulled low and the device is in standby.

Output Over-Voltage Detection (OVD), Under-Voltage Detection (UVD) and Enhanced Dynamic Response (EDR)

During normal operation, small perturbations on the PFC output voltage rarely exceed $\pm 5\%$ deviation and the normal voltage control loop gain drives the output back into regulation. For large changes in line or load, if the output voltage perturbation exceeds $\pm 5\%$, an output over-voltage (OVD) or under-voltage (UVD) is detected and Enhanced Dynamic Response (EDR) acts to speed up the slow response of the low-bandwidth voltage loop. During EDR, the transconductance of the voltage error amplifier is increased approximately five times to speed charging or discharging the voltage-loop compensation capacitors to the level required for regulation. EDR is disabled when $5.25\text{ V} > V_{\text{SENSE}} > 4.75\text{ V}$. The EDR feature is not activated until soft start is completed. The UVD is disabled during soft over protection (SOC) condition (since UVD and SOC conflict with each other).

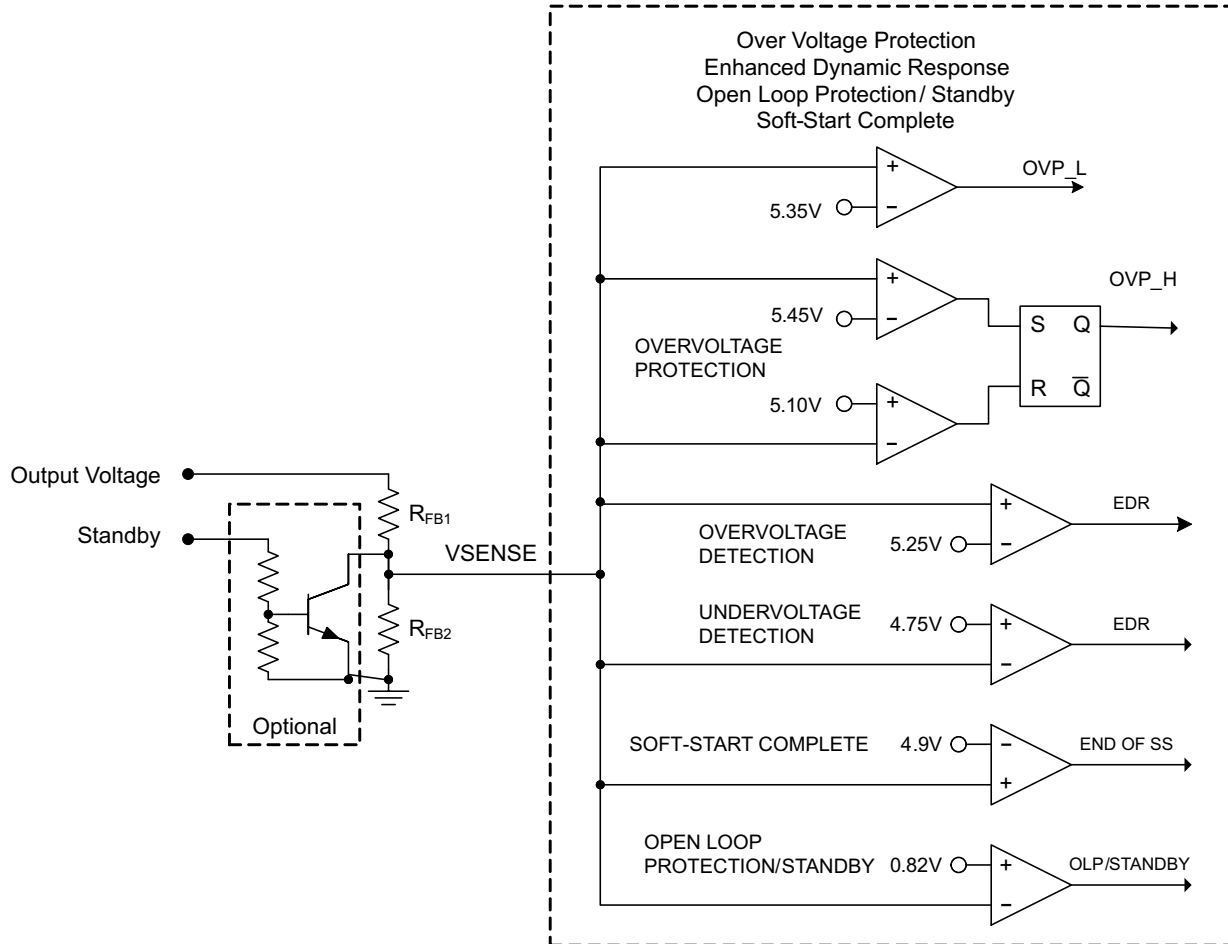

Figure 26. OVP_H, OVP_L, EDR, OLP, Soft Start Complete

Over-Current Protection

Inductor current is sensed by R_{ISENSE} , a low value resistor in the return path of input rectifier. The other side of the resistor is tied to the system ground. The voltage is sensed on the rectifier side of the sense resistor and is always negative. The voltage at ISENSE is buffered by a fixed gain of -2.5 to provide a positive internal signal to the current functions. There are two over-current protection features; Soft Over-Current (SOC) protects against an overload on the output and Peak Current Limit (PCL) protects against inductor saturation.

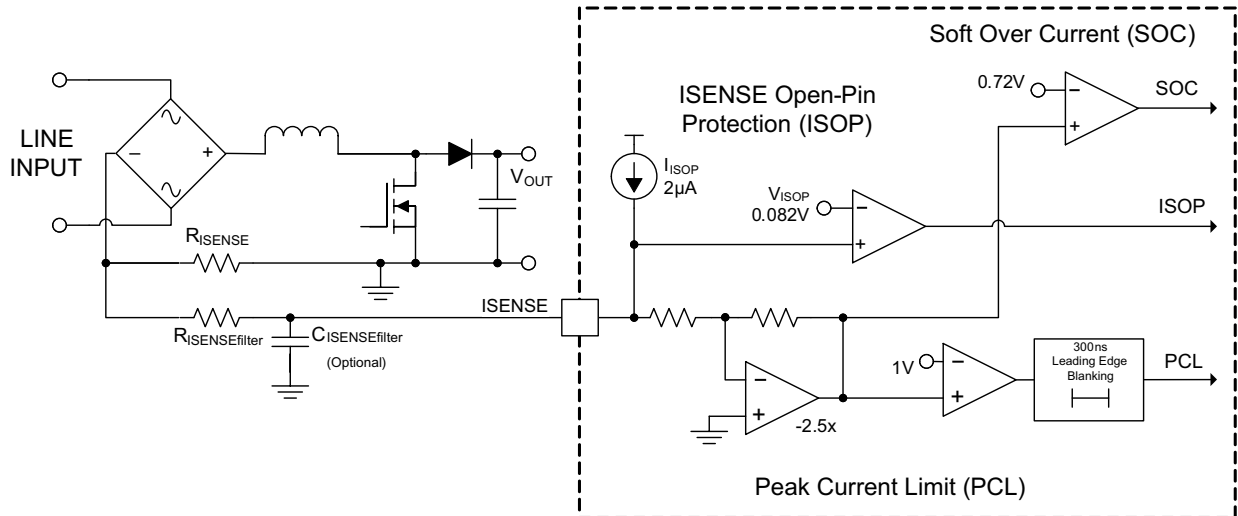

Figure 27. Soft Over-Current/Peak-Current Limit

Soft Over-Current (SOC)

Soft Over-Current (SOC) limits the input current. SOC is activated when the current sense voltage on ISENSE reaches -0.285 V . This is a soft control as it does not directly switch off the gate driver. Instead a $4\text{-k}\Omega$ resistor connects VCOMP to ground to discharges VCOMP and the control loop is adjusted to reduce the PWM duty cycle. The under-voltage detection (UVD) is disabled during SOC.

Peak Current Limit (PCL)

Peak Current Limit (PCL) operates on a cycle-by-cycle basis. When the current sense voltage on ISENSE reaches -0.4 V , PCL is activated, immediately terminating the active switch cycle. PCL is leading-edge blanked to improve noise immunity against false triggering.

Current Sense Resistor, R_{ISENSE}

The current sense resistor, R_{ISENSE} , is sized using the minimum threshold value of Soft Over Current (SOC), $V_{SOC(min)}$. To avoid triggering this threshold during normal operation, resulting in a decreased duty-cycle, the resistor is sized for an overload current of 10% more than the peak inductor current,

$$R_{ISENSE} \leq \frac{V_{SOC(min)}}{1.1 I_{L_PEAK(max)}} \tag{1}$$

Since R_{ISENSE} “sees” the average input current, worst-case power dissipation occurs at input low-line when input current is at its maximum. Power dissipated by the sense resistor is given by:

$$P_{RISENSE} = (I_{IN_RMS(max)})^2 R_{ISENSE} \tag{2}$$

Peak current limit (PCL) protection turns off the output driver when the voltage across the sense resistor reaches the PCL threshold, V_{PCL} . The absolute maximum peak current, I_{PCL} , is given by:

$$I_{PCL} = \frac{V_{PCL} / 2.5}{R_{ISENSE}} \tag{3}$$

Gate Driver

The GATE output is designed with a current-optimized structure to directly drive large values of total MOSFET/IGBT gate capacitance at high turn-on and turn-off speeds. An internal clamp limits voltage on the MOSFET gate to 15.2 V (typical). When V_{CC} voltage is below the UVLO level, the GATE output is held in the off state. An external gate drive resistor, R_{GATE} , can be used to limit the rise and fall times and dampen ringing caused by parasitic inductances and capacitances of the gate drive circuit and to reduce EMI. The final value of the resistor depends upon the parasitic elements associated with the layout and other considerations. A 10-k Ω resistor close to the gate of the MOSFET/IGBT, between the gate and ground, discharges stray gate capacitance and helps protect against inadvertent dv/dt-triggered turn-on.

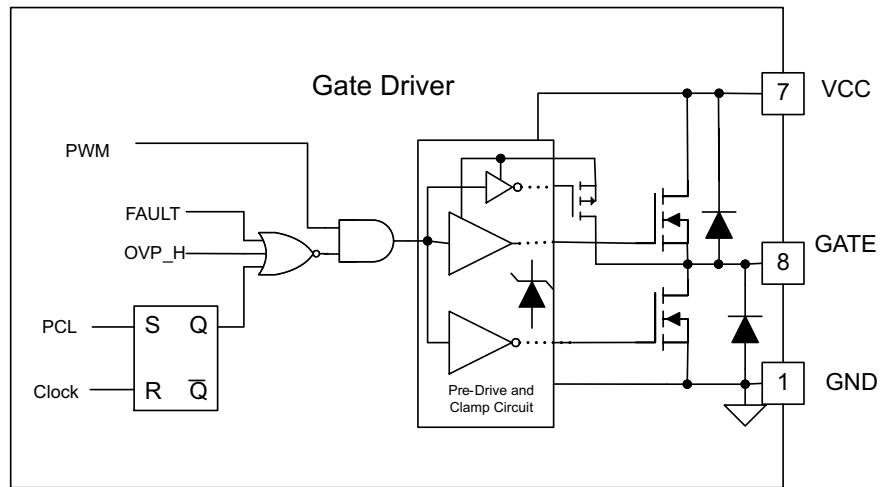

Figure 28. Gate Driver

Current Loop

The overall system current loop consists of the current averaging amplifier stage, the pulse width modulator (PWM) stage, the external boost inductor stage and the external current sensing resistor.

ISENSE and ICOMP Functions

The negative polarity signal from the current sense resistor is buffered and inverted at the ISENSE input. The internal positive signal is then averaged by the current amplifier (g_{mi}), whose output is the ICOMP pin. The voltage on ICOMP is proportional to the average inductor current. An external capacitor to GND is applied to the ICOMP pin for current loop compensation and current ripple filtering. The gain of the averaging amplifier is determined by the internal VCOMP voltage. This gain is non-linear to accommodate the world-wide AC-line voltage range.

ICOMP is connected to 3-V internally whenever OVP_H, ISOP, or OLP is triggered.

Pulse Width Modulator

The PWM stage compares the ICOMP signal with a periodic ramp to generate a leading-edge-modulated output signal which is high whenever the ramp voltage exceeds the ICOMP voltage. The slope of the ramp is defined by a non-linear function of the internal VCOMP voltage.

The PWM output signal always starts low at the beginning of the cycle, triggered by the internal clock. The output stays low for a minimum off-time, t_{OFF_min} , after which the ramp rises linearly to intersect the ICOMP voltage. The ramp-ICOMP intersection determines t_{OFF} , and hence D_{OFF} . Since $D_{OFF} = V_{IN}/V_{OUT}$ by the boost-topology equation, and since V_{IN} is sinusoidal in wave-shape, and since ICOMP is proportional to the inductor current, it follows that the control loop forces the inductor current to follow the input voltage wave-shape to maintain boost regulation. Therefore, the average input current is also sinusoidal in wave-shape.

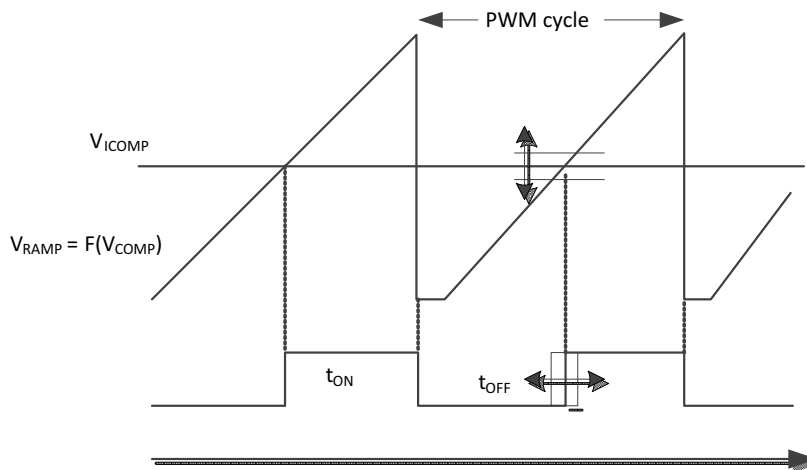

Figure 29. PWM Generation

Control Logic

The output of the PWM comparator stage is conveyed to the GATE drive stage, subject to control by various protection functions incorporated into the device. The GATE output duty-cycle may be as high as 98%, but always has a minimum off-time t_{OFF_min} . Normal duty-cycle operation can be interrupted directly by OVP_H and PCL. UVLO, ISOP, ICOMMP and OLP/Standby also terminate the GATE output pulse, and further inhibit output until the SS operation can begin.

Voltage Loop

The outer control loop of the PFC controller is the voltage loop. This loop consists of the PFC output sensing stage, the voltage error amplifier stage, and the non-linear gain generation.

Output Sensing

A resistor-divider network from the PFC output voltage to GND forms the sensing block for the voltage control loop. The resistor ratio is determined by the desired output voltage and the internal 5-V regulation reference voltage.

The very low bias current at the VSENSE input allows the choice of the highest practicable resistor values for lowest power dissipation and standby current. A small capacitor from VSENSE to GND serves to filter the signal in a high-noise environment. This filter time constant should generally be less than 100 μ s.

Voltage Error Amplifier

The transconductance error amplifier (g_{mv}) generates an output current proportional to the difference between the voltage feedback signal at VSENSE and the internal 5-V reference. This output current charges or discharges the compensation network capacitors on the VCOMP pin to establish the proper VCOMP voltage for the system operating conditions. Proper selection of the compensation network components leads to a stable PFC pre-regulator over the entire AC-line range and 0% to 100% load range. The total capacitance also determines the rate-of-rise of the VCOMP voltage at *Soft Start*, as discussed earlier.

The amplifier output VCOMP is pulled to GND during any fault or standby condition to discharge the compensation capacitors to an initial zero state. Usually, the large capacitor has a series resistor which delays complete discharge for their respective time constant (which may be several hundred milliseconds). If VCC bias voltage is quickly removed after UVLO, the normal discharge transistor on VCOMP loses drive and the large capacitor could be left with substantial voltage on it, negating the benefit of a subsequent *Soft Start*. The UCC28180 incorporates a parallel discharge path which operates without VCC bias, to further discharge the compensation network after VCC is removed.

If the output voltage perturbations exceed $\pm 5\%$, and output over-voltage (OVD) or under-voltage (UVD) is detected, the OVD or UVD function invokes EDR which immediately increases the voltage error amplifier transconductance to about 280 μ S. This higher gain facilitates faster charging or discharging the compensation capacitors to the new operating level. When output voltage perturbations greater than $107\%V_{REF}$ appear at the VSENSE input, a 4-k Ω resistor connects VCOMP to ground to quickly reduce VCOMP voltage. When output voltage perturbations are greater than $109\%V_{REF}$, the GATE output is shut off until VSENSE drops below 102% of regulation.

Non-Linear Gain Generation

The voltage at VCOMP is used to set the current amplifier gain and the PWM ramp slope. This voltage is subject to modification by the SOC function, as discussed earlier.

Together the current gain and the PWM slope adjust to the different system operating conditions (set by the AC-line voltage and output load level) as VCOMP changes, to provide a low-distortion, high-power-factor, input-current wave shape following that of the input voltage.

Design Example

Design Goals

This example illustrates the design process and component selection for a continuous mode power factor correction boost converter utilizing the UCC28180. The pertinent design equations are shown for a universal input, 360-W PFC converter with an output voltage of 390 V.

Table 1. Design Goal Parameters

PARAMETER		TEST CONDITION	MIN	TYP	MAX	UNIT
Input Characteristics						
V_{IN}	Input voltage		85		265	V_{AC}
f_{LINE}	Input frequency		47		63	Hz
$I_{IN(peak)}$	Peak input current	$V_{IN} = V_{IN(min)}$, $I_{OUT} = I_{OUT(max)}$		7		A
Output Characteristics						
V_{OUT}	Output voltage	$V_{IN(min)} \leq V_{IN} \leq V_{IN(max)}$, $f_{LINE(min)} \leq f_{LINE} \leq f_{LINE(max)}$, $I_{OUT} \leq I_{OUT(max)}$	379	390	402	VDC
	Line Regulation	$V_{IN(min)} \leq V_{IN} \leq V_{IN(max)}$, $I_{OUT} = I_{OUT(max)}$			5%	
	Load Regulation	$V_{IN} = 115 V_{AC}$, $f_{LINE} = 60 \text{ Hz}$, $I_{OUT(min)} \leq I_{OUT} \leq I_{OUT(max)}$			5%	
		$V_{IN} = 230 V_{AC}$, $f_{LINE} = 60 \text{ Hz}$, $I_{OUT(min)} \leq I_{OUT} \leq I_{OUT(max)}$			5%	
I_{OUT}	Output Load Current	$V_{IN(min)} \leq V_{IN} \leq V_{IN(max)}$, $f_{LINE(min)} \leq f_{LINE} \leq f_{LINE(max)}$	0		0.923	A
P_{OUT}	Output Power	$V_{IN(min)} \leq V_{IN} \leq V_{IN(max)}$, $f_{LINE(min)} \leq f_{LINE} \leq f_{LINE(max)}$	0		360	W
$V_{RIPPLE(SW)}$	High frequency Output voltage ripple	$V_{IN} = 115 V_{AC}$, $f_{LINE} = 60 \text{ Hz}$, $I_{OUT} = I_{OUT(max)}$		2.5	3.9	V_{P-P}
		$V_{IN} = 230 V_{AC}$, $f_{LINE} = 50 \text{ Hz}$, $I_{OUT} = I_{OUT(max)}$		2.5	3.9	
$V_{RIPPLE(f_{LINE})}$	Line frequency Output voltage ripple	$V_{IN} = 115 V_{AC}$, $f_{LINE} = 60 \text{ Hz}$, $I_{OUT} = I_{OUT(max)}$		11.6	19.5	V_{P-P}
		$V_{IN} = 230 V_{AC}$, $f_{LINE} = 50 \text{ Hz}$, $I_{OUT} = I_{OUT(max)}$		13.3	19.5	
$V_{OUT(OVP)}$	Output over voltage protection			425		V
$V_{OUT(UVP)}$	Output under voltage protection			370		

Table 1. Design Goal Parameters (continued)

PARAMETER		TEST CONDITION	MIN	TYP	MAX	UNIT
Control Loop Characteristics						
f_{SW}	Switching frequency	$T_J = 25^\circ\text{C}$	114	120	126	kHz
$f_{(CO)}$	Voltage Loop Bandwidth	$V_{IN} = 162\text{ VDC},$ $I_{OUT} = 0.466\text{ A}$		8		Hz
	Voltage Loop Phase Margin	$V_{IN} = 162\text{ VDC},$ $I_{OUT} = 0.466\text{ A}$		68		°
PF	Power Factor	$V_{IN} = 115\text{ VAC},$ $I_{OUT} = I_{OUT(max)}$		0.99		
THD	Total harmonic distortion	$V_{IN} = 115\text{ VAC},$ $f_{LINE} = 60\text{ Hz},$ $I_{OUT} = I_{OUT(max)}$		4.3%	10%	
		$V_{IN} = 230\text{ VAC},$ $f_{LINE} = 50\text{ Hz},$ $I_{OUT} = I_{OUT(max)}$		4%	10%	
η	Full load efficiency	$V_{IN} = 115\text{ VAC},$ $f_{LINE} = 60\text{ Hz},$ $I_{OUT} = I_{OUT(max)}$		94%		
	Ambient temperature			25		°C

The following procedure refers to the schematic shown in Figure 30.

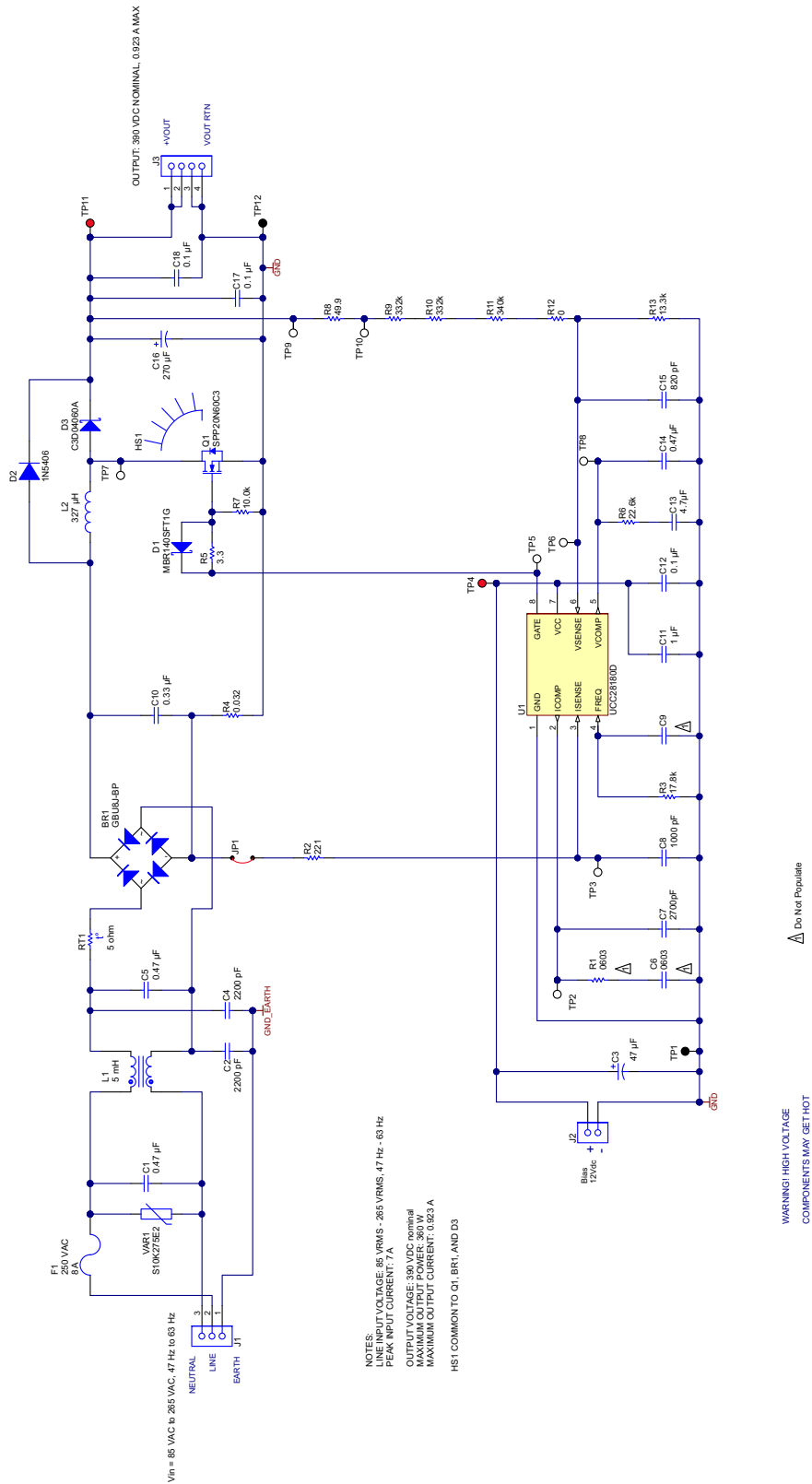

Figure 30. Design Example Schematic

Current Calculations

The input fuse, bridge rectifier, and input capacitor are selected based upon the input current calculations. First, determine the maximum average output current, $I_{OUT(max)}$:

$$I_{OUT(max)} = \frac{P_{OUT(max)}}{V_{OUT}} \quad (4)$$

$$I_{OUT(max)} = \frac{360 \text{ W}}{390 \text{ V}} \cong 0.923 \text{ A} \quad (5)$$

The maximum input RMS line current, $I_{IN_RMS(max)}$, is calculated using the parameters from [Table 1](#) and the efficiency and power factor initial assumptions:

$$I_{IN_RMS(max)} = \frac{P_{OUT(max)}}{\eta V_{IN(min)} PF} \quad (6)$$

$$I_{IN_RMS(max)} = \frac{360 \text{ W}}{0.94 \times 85 \text{ V} \times 0.99} = 4.551 \text{ A} \quad (7)$$

Based upon the calculated RMS value, the maximum input current, $I_{IN(max)}$, and the maximum average input current, $I_{IN_AVG(max)}$, assuming the waveform is sinusoidal, can be determined.

$$I_{IN(max)} = \sqrt{2} I_{IN_RMS(max)} \quad (8)$$

$$I_{IN(max)} = \sqrt{2} \times 4.551 \text{ A} = 6.436 \text{ A} \quad (9)$$

$$I_{IN_AVG(max)} = \frac{2 I_{IN(max)}}{\pi} \quad (10)$$

$$I_{IN_AVG(max)} = \frac{2 \times 6.436 \text{ A}}{\pi} = 4.097 \text{ A} \quad (11)$$

The Switching Frequency

The UCC28180 switching frequency is user programmable with a single resistor on the FREQ pin to ground. For this design, the switching frequency, f_{SW} , was chosen to be 120 kHz. Figure 31 (same as Figure 1) could be used to select the suitable resistor to program the switching frequency or the value can be calculated using constant scaling values of f_{TYP} and R_{TYP} . In all cases, f_{TYP} is a constant that is equal to 65 kHz, R_{INT} is a constant that is equal to 1 M Ω , and R_{TYP} is a constant that is equal to 32.7 k Ω . Simply applying the calculation below yields the appropriate resistor that should be placed between FREQ and GND:

$$R_{FREQ} = \frac{f_{TYP} \times R_{TYP} \times R_{INT}}{(f_{SW} \times R_{INT}) + (R_{TYP} \times f_{SW}) - (R_{TYP} \times f_{TYP})} \quad (12)$$

$$R_{FREQ} = \frac{65\text{kHz} \times 32.7\text{k}\Omega \times 1\text{M}\Omega}{(120\text{kHz} \times 1\text{M}\Omega) + (32.7\text{k}\Omega \times 120\text{kHz}) - (32.7\text{k}\Omega \times 65\text{kHz})} = 17.451\text{k}\Omega \quad (13)$$

A typical value of 17.8 k Ω for the FREQ resistor results in a switching frequency of 118 kHz.

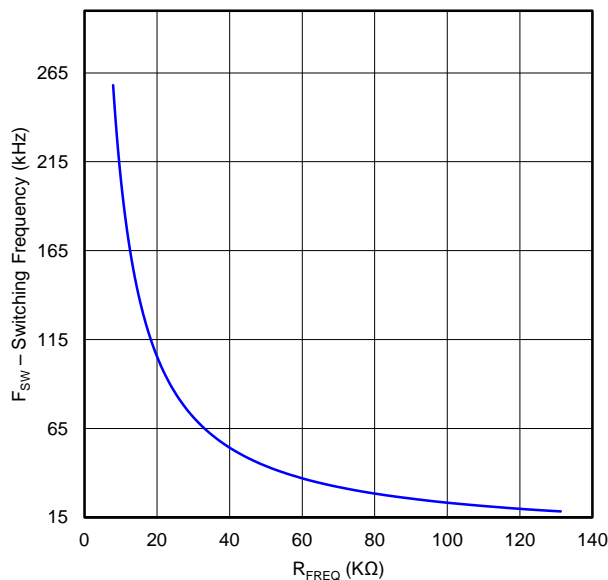

Figure 31. Frequency vs. R_{FREQ}

Bridge Rectifier

The input bridge rectifier must have an average current capability that exceeds the input average current. Assuming a forward voltage drop, V_{F_BRIDGE} , of 1 V across the rectifier diodes, BR1, the power loss in the input bridge, P_{BRIDGE} , can be calculated:

$$P_{BRIDGE} = 2V_{F_BRIDGE}I_{IN_AVG(max)} \quad (14)$$

$$P_{BRIDGE} = 2 \times 1V \times 4.097 A = 8.195 W \quad (15)$$

Heat sinking will be required to maintain operation within the bridge rectifier's safe operating area.

Inductor Ripple Current

The UCC28180 is a Continuous Conduction Mode (CCM) controller but if the chosen inductor allows relatively high-ripple current, the converter will be forced to operate in Discontinuous Mode (DCM) at light loads and at the higher input voltage range. High-inductor ripple current has an impact on the CCM/DCM boundary and results in higher light-load THD, and also affects the choices for the input capacitor, R_{SENSE} and C_{ICOMP} values. Allowing an inductor ripple current, ΔI_{RIPPLE} , of 20% or less will result in CCM operation over the majority of the operating range but requires a boost inductor that has a higher inductance value and the inductor itself will be physically large. As with all converter designs, decisions must be made at the onset in order to optimize performance with size and cost. In this design example, the inductor is sized in such a way as to allow a greater amount of ripple current in order to minimize space with the understanding that the converter operates in DCM at the higher input voltages and at light loads but optimized for a nominal input voltage of 115 V_{AC} at full load. Although specifically defined as a CCM controller, the UCC28180 is shown in this application to meet the overall performance goals while transitioning into DCM at high-line voltage, at a higher load level.

Input Capacitor

The input capacitor must be selected based upon the input ripple current and an acceptable high frequency input voltage ripple. Allowing an inductor ripple current, ΔI_{RIPPLE} , of 40% and a high frequency voltage ripple factor, ΔV_{RIPPLE_IN} , of 7%, the maximum input capacitor value, C_{IN} , is calculated by first determining the input ripple current, I_{RIPPLE} , and the input voltage ripple, V_{IN_RIPPLE} :

$$I_{RIPPLE} = \Delta I_{RIPPLE} I_{IN(max)} \quad (16)$$

$$\Delta I_{RIPPLE} = 0.4 \quad (17)$$

$$I_{RIPPLE} = 0.4 \times 6.436 A = 2.575 A \quad (18)$$

$$V_{IN_RIPPLE} = \Delta V_{RIPPLE_IN} V_{IN_RECTIFIED(min)} \quad (19)$$

$$\Delta V_{RIPPLE_IN} = 0.07 \quad (20)$$

$$V_{IN_RECTIFIED} = \sqrt{2} V_{IN} \quad (21)$$

$$V_{IN_RECTIFIED} = \sqrt{2} \times 85 V = 120 V \quad (22)$$

$$V_{IN_RIPPLE} = 0.07 \times 120 V = 8.415 V \quad (23)$$

The recommended value for the input x-capacitor can now be calculated:

$$C_{IN} = \frac{I_{RIPPLE}}{8f_{SW} V_{IN_RIPPLE}} \quad (24)$$

$$C_{IN} = \frac{2.575 A}{8 \times 118 kHz \times 8.415 V} = 0.324 \mu F \quad (25)$$

A standard value 0.33- μF Y2/X2 film capacitor is used.

Boost Inductor

Based upon the allowable inductor ripple current discussed above, the boost inductor, L_{BST} , is selected after determining the maximum inductor peak current, I_{L_PEAK} :

$$I_{L_PEAK(max)} = I_{IN(max)} + \frac{I_{RIPPLE}}{2} \quad (26)$$

$$I_{L_PEAK(max)} = 6.436 \text{ A} + \frac{2.575 \text{ A}}{2} = 7.724 \text{ A} \quad (27)$$

The minimum value of the boost inductor is calculated based upon the acceptable ripple current, I_{RIPPLE} , at a worst case duty cycle of 0.5:

$$L_{BST(min)} \geq \frac{V_{OUT}D(1-D)}{f_{SW}I_{RIPPLE}} \quad (28)$$

$$L_{BST(min)} \geq \frac{390 \text{ V} \times 0.5(1-0.5)}{118 \text{ kHz} \times 2.575 \text{ A}} \geq 321 \mu\text{H} \quad (29)$$

The recommended minimum value for the boost inductor assuming a 40% ripple current is 321 μH ; the actual value of the boost inductor that will be used is 327 μH . With this actual value used, the actual resultant inductor current ripple will be:

$$L_{BST} = 327 \mu\text{H} \quad (30)$$

$$I_{RIPPLE(actual)} = \frac{V_{OUT}D(1-D)}{f_{SW}L_{BST}} \quad (31)$$

$$I_{RIPPLE(actual)} = \frac{390 \text{ V} \times 0.5(1-0.5)}{118 \text{ kHz} \times 327 \mu\text{H}} = 2.527 \text{ A} \quad (32)$$

$$I_{L_PEAK(max)} = 6.436 \text{ A} + \frac{2.527 \text{ A}}{2} = 7.7 \text{ A} \quad (33)$$

The duty cycle is a function of the rectified input voltage and will be continuously changing over the half line cycle. The duty cycle, $DUTY_{(max)}$, can be calculated at the peak of the minimum input voltage:

$$DUTY_{(max)} = \frac{V_{OUT} - V_{IN_RECTIFIED(min)}}{V_{OUT}} \quad (34)$$

$$V_{IN_RECTIFIED(min)} = \sqrt{2} \times 85 \text{ V} = 120 \text{ V} \quad (35)$$

$$DUTY_{(max)} = \frac{390 \text{ V} - 120 \text{ V}}{390 \text{ V}} = 0.692 \quad (36)$$

Boost Diode

The diode losses are estimated based upon the forward voltage drop, V_F , at 125°C and the reverse recovery charge, Q_{RR} , of the diode. Using a silicon carbide Schottky diode, although more expensive, will essentially eliminate the reverse recovery losses and result in less power dissipation:

$$P_{DIODE} = V_{F_125C} I_{OUT(max)} + 0.5 f_{SW} V_{OUT} Q_{RR} \quad (37)$$

$$V_{F_125C} = 1 \text{ V} \quad (38)$$

$$Q_{RR} = 0 \text{ nC} \quad (39)$$

$$P_{DIODE} = (1 \text{ V} \times 0.923 \text{ A}) + (0.5 \times 119 \text{ kHz} \times 390 \text{ V} \times 0 \text{ nC}) = 0.923 \text{ W} \quad (40)$$

This output diode should have a blocking voltage that exceeds the output over voltage of the converter and be attached to an appropriately sized heat sink.

Switching Element

The MOSFET/IGBT switch will be driven by a GATE output that is clamped at 15.2 V for VCC bias voltages greater than 15.2 V. An external gate drive resistor is recommended to limit the rise time and to dampen any ringing caused by the parasitic inductances and capacitances of the gate drive circuit; this will also help in meeting any EMI requirements of the converter. The design example uses a 3.3-Ω resistor; the final value of any design is dependent upon the parasitic elements associated with the layout of the design. To facilitate a fast turn off, a standard 40-V, 1-A Schottky diode is placed anti-parallel with the gate drive resistor. A 10-kΩ resistor is placed between the gate of the MOSFET/IGBT and ground to discharge the gate capacitance and protect from inadvertent dv/dt triggered turn-on.

The conduction losses of the switch MOSFET, in this design are estimated using the $R_{DS(on)}$ at 125°C, found in the device data sheet, and the calculated drain to source RMS current, I_{DS_RMS} :

$$P_{COND} = I_{DS_RMS}^2 R_{DS(on)125^\circ C} \quad (41)$$

$$R_{DS(on)125^\circ C} = 0.35 \Omega \quad (42)$$

$$I_{DS_RMS} = \frac{P_{OUT(max)}}{V_{IN_RECTIFIED(min)}} \sqrt{2 - \frac{16V_{IN_RECTIFIED(min)}}{3\pi V_{OUT}}} \quad (43)$$

$$I_{DS_RMS} = \frac{360 W}{120 V} \sqrt{2 - \frac{16 \times 120 V}{3\pi \times 390 V}} = 3.639 A \quad (44)$$

$$P_{COND} = 3.639 A^2 \times 0.35 \Omega = 4.636 W \quad (45)$$

The switching losses are estimated using the rise time, t_r , and fall time, t_f , of the MOSFET gate, and the output capacitance losses.

$$t_r = 5 ns$$

$$t_f = 4.5 ns$$

$$C_{OSS} = 780 pF \quad (46)$$

$$P_{SW} = f_{SW} \left[0.5 V_{OUT} I_{IN(max)} (t_r + t_f) + 0.5 C_{OSS} V_{OUT}^2 \right] \quad (47)$$

$$P_{SW} = 118 kHz \left[0.5 \times 390 V \times 6.436 A (5 ns + 4.5 ns) + 0.5 \times 780 pF \times 390 V^2 \right] = 8.407 W \quad (48)$$

Total FET losses

$$P_{COND} + P_{SW} = 4.636 W + 8.407 W = 13.042 W \quad (49)$$

The MOSFET requires an appropriately sized heat sink.

Sense Resistor

To accommodate the gain of the non-linear power limit, the sense resistor, R_{SENSE} , is sized such that it triggers the soft over current at 10% higher than the maximum peak inductor current using the minimum soft over current threshold of the ISENSE pin, V_{SOC} , of ISENSE equal to 0.265 V.

$$R_{\text{SENSE}} = \frac{V_{\text{SOC}(\text{min})}}{I_{\text{L_PEAK}(\text{max})} \times 1.1} \quad (50)$$

$$R_{\text{SENSE}} = \frac{0.259 \text{ V}}{7.7 \text{ A} \times 1.1} = 0.032 \Omega \quad (51)$$

The power dissipated across the sense resistor, P_{RSENSE} , must be calculated:

$$P_{\text{RSENSE}} = I_{\text{IN_RMS}(\text{max})}^2 R_{\text{SENSE}} \quad (52)$$

$$P_{\text{RSENSE}} = 4.551 \text{ A}^2 \times 0.032 \Omega = 0.663 \text{ W} \quad (53)$$

The peak current limit, PCL, protection feature is triggered when current through the sense resistor results in the voltage across R_{SENSE} to be equal to the V_{PCL} threshold. For a worst case analysis, the maximum V_{PCL} threshold is used:

$$I_{\text{PCL}} = \frac{V_{\text{PCL}(\text{max})}}{R_{\text{SENSE}}} \quad (54)$$

$$I_{\text{PCL}} = \frac{0.438 \text{ V}}{0.032 \Omega} = 13.688 \text{ A} \quad (55)$$

To protect the device from inrush current, a standard 220- Ω resistor, R_{ISENSE} , is placed in series with the ISENSE pin. A 1000-pF capacitor is placed close to the device to improve noise immunity on the ISENSE pin.

Output Capacitor

The output capacitor, C_{OUT} , is sized to meet holdup requirements of the converter. Assuming the downstream converters require the output of the PFC stage to never fall below 300 V, $V_{OUT_HOLDUP(min)}$, during one line cycle, $t_{HOLDUP} = 1/f_{LINE(min)}$, the minimum calculated value for the capacitor is:

$$C_{OUT(min)} \geq \frac{2P_{OUT(max)}t_{HOLDUP}}{V_{OUT}^2 - V_{OUT_HOLDUP(min)}^2} \quad (56)$$

$$C_{OUT(min)} \geq \frac{2 \times 360 \text{ W} \times 21.28 \text{ ms}}{390 \text{ V}^2 - 300 \text{ V}^2} \geq 247 \mu\text{F} \quad (57)$$

It is advisable to de-rate this capacitor value by 10%; the actual capacitor used is 270 μF .

Verifying that the maximum peak-to-peak output ripple voltage will be less than 5% of the output voltage ensures that the ripple voltage will not trigger the output over-voltage or output under-voltage protection features of the controller. If the output ripple voltage is greater than 5% of the regulated output voltage, a larger output capacitor is required. The maximum peak-to-peak ripple voltage, occurring at twice the line frequency, and the ripple current of the output capacitor is calculated:

$$V_{OUT_RIPPLE(pp)} < 0.05 V_{OUT} \quad (58)$$

$$V_{OUT_RIPPLE(pp)} < 0.05 \times 390 \text{ V} = 19.5 \text{ V}_{PP} \quad (59)$$

$$V_{OUT_RIPPLE(pp)} = \frac{I_{OUT}}{2\pi(2f_{LINE(min)})C_{OUT}} \quad (60)$$

$$V_{OUT_RIPPLE(pp)} = \frac{0.923 \text{ A}}{2\pi(2 \times 47 \text{ Hz}) \times 270 \mu\text{F}} = 5.789 \text{ V} \quad (61)$$

The required ripple current rating at twice the line frequency is equal to:

$$I_{COUT_2fline} = \frac{I_{OUT(max)}}{\sqrt{2}} \quad (62)$$

$$I_{COUT_2fline} = \frac{0.923 \text{ A}}{\sqrt{2}} = 0.653 \text{ A} \quad (63)$$

There is a high frequency ripple current through the output capacitor:

$$I_{COUT_HF} = I_{OUT(max)} \sqrt{\frac{16 V_{OUT}}{3\pi V_{IN_RECTIFIED(min)}} - 1.5} \quad (64)$$

$$I_{COUT_HF} = 0.923 \text{ A} \sqrt{\frac{16 \times 390 \text{ V}}{3\pi \times 120 \text{ V}} - 1.5} = 1.848 \text{ A} \quad (65)$$

The total ripple current in the output capacitor is the combination of both and the output capacitor must be selected accordingly:

$$I_{COUT_RMS(total)} = \sqrt{I_{COUT_2fline}^2 + I_{COUT_HF}^2} \quad (66)$$

$$I_{COUT_RMS(total)} = \sqrt{0.653 \text{ A}^2 + 1.848 \text{ A}^2} = 1.96 \text{ A} \quad (67)$$

Output Voltage Set Point

For low power dissipation and minimal contribution to the voltage set point, it is recommended to use 1 M Ω for the top voltage feedback divider resistor, R_{FB1}. Multiple resistors in series are used due to the maximum allowable voltage across each. Using the internal 5-V reference, V_{REF}, the bottom divider resistor, R_{FB2}, is selected to meet the output voltage design goals.

$$R_{FB2} = \frac{V_{REF}R_{FB1}}{V_{OUT} - V_{REF}} \quad (68)$$

$$R_{FB2} = \frac{5\text{ V} \times 1\text{ M}\Omega}{390\text{ V} - 5\text{ V}} = 13.04\text{ k}\Omega \quad (69)$$

A standard value 13-k Ω resistor for R_{FB2} results in a nominal output voltage set point of 391 V.

An output over voltage is detected when the output voltage exceeds its nominal set-point level by 5%, as measured when the voltage at VSENSE is 105% of the reference voltage, V_{REF}. At this threshold, the enhanced dynamic response (EDR) is triggered and the non-linear gain to the voltage error amplifier will increase the transconductance to VCOMP and quickly return the output to its normal regulated value. This EDR threshold occurs when the output voltage reaches the V_{OUT(ovd)} level:

$$V_{OVD} = 1.05 V_{REF} = 1.05 \times 5\text{ V} = 5.25\text{ V} \quad (70)$$

$$V_{OUT(ovd)} = V_{OVD} \left(\frac{R_{FB1} + R_{FB2}}{R_{FB2}} \right) \quad (71)$$

$$V_{OUT(ovd)} = 5.25\text{ V} \times \left(\frac{1\text{ M}\Omega + 13\text{ k}\Omega}{13\text{ k}\Omega} \right) = 410.7\text{ V} \quad (72)$$

In the event of an extreme output over voltage event, the GATE output will be disabled if the output voltage exceeds its nominal set-point value by 9%. The output voltage, V_{OUT(ovp)}, at which this protection feature is triggered is calculated as follows:

$$V_{OUT(ovp)} = 1.09 \times V_{REF} \left(\frac{R_{FB1} + R_{FB2}}{R_{FB2}} \right) = 426.4\text{ V} \quad (73)$$

An output under voltage is detected when the output voltage falls below 5% below its nominal set-point as measured when the voltage at VSENSE is 95% of the reference voltage, V_{REF}:

$$V_{UVD} = 0.95 V_{REF} = 0.95 \times 5\text{ V} = 4.75\text{ V} \quad (74)$$

$$V_{OUT(uvp)} = V_{UVD} \left(\frac{R_{FB1} + R_{FB2}}{R_{FB2}} \right) \quad (75)$$

$$V_{OUT(uvp)} = 4.75\text{ V} \times \left(\frac{1\text{ M}\Omega + 13\text{ k}\Omega}{13\text{ k}\Omega} \right) = 371.6\text{ V} \quad (76)$$

A small capacitor on VSENSE must be added to filter out noise. Limit the value of the filter capacitor such that the RC time constant is limited to approximately 10 μ s so as not to significantly reduce the control response time to output voltage deviations.

$$C_{VSENSE} = \frac{10\mu\text{s}}{R_{FB2}} = 769\text{ pF} \quad (77)$$

The closest standard value of 820 pF was used on VSENSE for a time constant of 10.66 μ s.

Loop Compensation

The current loop is compensated first by determining the product of the internal loop variables, M_1M_2 , using the internal controller constants K_1 and K_{FQ} . Compensation is optimized maximum load and nominal input voltage, 115 V_{AC} is used for the nominal line voltage for this design:

$$M_1M_2 = \frac{I_{OUT(max)} V_{OUT}^2 2.5R_{SENSE} K_1}{\eta V_{IN_RMS}^2 K_{FQ}} \quad (78)$$

$$K_{FQ} = \frac{1}{f_{SW}}$$

$$K_{FQ} = \frac{1}{118\text{kHz}} = 8.475\mu\text{s}$$

$$K_1 = 7 \quad (79)$$

$$M_1M_2 = \frac{0.923\text{A} \times 390\text{V}^2 \times 2.5 \times 0.032\Omega \times 7}{0.92 \times 115\text{V}^2 \times 8.475\mu\text{s}} = 0.751 \frac{\text{V}}{\mu\text{s}} \quad (80)$$

The VCOMP operating point is found on the following chart, M_1M_2 vs. VCOMP. Once the M_1M_2 result is calculated above, find the resultant VCOMP voltage at that operating point to calculate the individual M_1 and M_2 components.

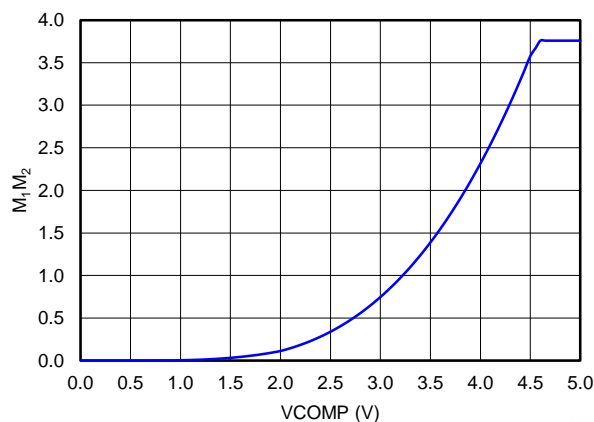

Figure 32. M1M2 vs. VCOMP

For the given M_1M_2 of 0.751 V/ μ s, the VCOMP approximately equal to 3 V, as shown in [Figure 32](#).

The individual loop factors, M_1 which is the current loop gain factor, and M_2 which is the voltage loop PWM ramp slope, are calculated using the following conditions:

The M_1 non-linear current loop gain factor follows the following identities:

$$M_1 = 0.068 \text{ if } V_{\text{COMP}} < 1 \text{ V} \quad (81)$$

$$M_1 = 0.156 \times V_{\text{COMP}} - 0.088 \text{ if } 1 \text{ V} < V_{\text{COMP}} < 2 \text{ V} \quad (82)$$

$$M_1 = 0.313 \times V_{\text{COMP}} - 0.401 \text{ if } 2 \text{ V} < V_{\text{COMP}} < 4.5 \text{ V} \quad (83)$$

$$M_1 = 1.007 \text{ if } 4.5 \text{ V} < V_{\text{COMP}} < 5 \text{ V} \quad (84)$$

In this example, according to the chart in [Figure 32](#), V_{COMP} is approximately equal to 3 V, so M_1 is calculated to be approximately equal to 0.538:

$$M_1 = 0.313 \times 2.45 - 0.401 = 0.366 \quad (85)$$

The M_2 non-linear PWM ramp slope will obey the following relationships:

$$M_2 = 0 \frac{\text{V}}{\mu\text{s}} \text{ if } V_{\text{COMP}} \leq 0.5 \text{ V} \quad (86)$$

$$M_2 = \frac{f_{\text{SW}}}{65\text{kHz}} \times 0.1223 \times (V_{\text{COMP}} - 0.5)^2 \frac{\text{V}}{\mu\text{s}} \text{ if } 0.5 \text{ V} \leq V_{\text{COMP}} \leq 4.6 \text{ V} \quad (87)$$

$$M_2 = \frac{f_{\text{SW}}}{65\text{kHz}} \times 2.056 \frac{\text{V}}{\mu\text{s}} \text{ if } 4.6 \text{ V} \leq V_{\text{COMP}} \leq 5 \text{ V} \quad (88)$$

In this example, with V_{COMP} approximately equal to 3 V, M_2 equals 1.388 V/ μ s:

$$M_2 = \frac{118\text{kHz}}{65\text{kHz}} \times 0.1223 \times (3 - 0.5)^2 \frac{\text{V}}{\mu\text{s}} = 1.388 \frac{\text{V}}{\mu\text{s}} \quad (89)$$

Verify that the product of the individual gain factors, M_1 and M_2 , is approximately equal to the M_1M_2 factor determined above, if not, iterate the V_{COMP} value and recalculate M_1M_2

$$M_1 \times M_2 = 0.538 \times 1.388 \frac{\text{V}}{\mu\text{s}} = 0.747 \frac{\text{V}}{\mu\text{s}} \quad (90)$$

The product of M_1 and M_2 is within 1% of the M_1M_2 factor previously calculated:

$$M_1 \times M_2 \cong M_1M_2 \quad (91)$$

$$0.747 \frac{\text{V}}{\mu\text{s}} \cong 0.751 \frac{\text{V}}{\mu\text{s}} \quad (92)$$

If more accuracy was desired, iteration results in a V_{COMP} value of 3.004 V where M_1M_2 and $M_1 \times M_2$ are both equal to 0.751 V/ μ s.

UCC28180

SLUSBQ5A –NOVEMBER 2013–REVISED NOVEMBER 2013

www.ti.com

The non-linear gain variable, M_3 , can now be calculated:

$$M_3 = 0 \text{ if } V_{\text{COMP}} < 5 \text{ V} \quad (93)$$

$$M_3 = \frac{f_{\text{SW}}}{65 \text{ kHz}} \times \frac{\text{V}}{\mu\text{s}} \times (0.0166 \times V_{\text{COMP}} - 0.0083) \quad \text{if } 0.5 \text{ V} < V_{\text{COMP}} < 1 \text{ V} \quad (94)$$

$$M_3 = \frac{f_{\text{SW}}}{65 \text{ kHz}} \times \frac{\text{V}}{\mu\text{s}} \times (0.0572 \times V_{\text{COMP}}^2 - 0.0597 \times V_{\text{COMP}} + 0.0155) \quad \text{if } 1 \text{ V} < V_{\text{COMP}} < 2 \text{ V} \quad (95)$$

$$M_3 = \frac{f_{\text{SW}}}{65 \text{ kHz}} \times \frac{\text{V}}{\mu\text{s}} \times (0.1148 \times V_{\text{COMP}}^2 - 0.1746 \times V_{\text{COMP}} + 0.0586) \quad \text{if } 2 \text{ V} < V_{\text{COMP}} < 4.5 \text{ V} \quad (96)$$

$$M_3 = \frac{f_{\text{SW}}}{65 \text{ kHz}} \times \frac{\text{V}}{\mu\text{s}} \times (0.1148 \times V_{\text{COMP}}^2 - 0.1746 \times V_{\text{COMP}} + 0.0586) \quad \text{if } 4.5 \text{ V} < V_{\text{COMP}} < 4.6 \text{ V} \quad (97)$$

$$M_3 = 0 \text{ if } 4.6 \text{ V} < V_{\text{COMP}} < 5 \text{ V} \quad (98)$$

In this example, using 3.004 V for V_{COMP} for a more precise calculation, M_3 calculates to 1.035 V/ μs :

$$M_3 = \frac{118 \text{ kHz}}{65 \text{ kHz}} \times \frac{\text{V}}{\mu\text{s}} \times (0.1148 \times 3.004^2 - 0.1746 \times 3.004 + 0.0586) = 1.035 \frac{\text{V}}{\mu\text{s}} \quad (99)$$

For designs that allow a high inductor ripple current, the current averaging pole, which functions to flatten out the ripple current on the input of the PWM comparator, should be at least decade before the converter switching frequency. Analysis on the completed converter may be needed to determine the ideal compensation pole for the current averaging circuit as too large of a capacitor on I_{COMP} will add phase lag and increase i_{THD} where as too small of an I_{COMP} capacitor will result in not enough averaging and an unstable current averaging loop. The frequency of the current averaging pole, $f_{\text{I AVG}}$, is chosen to be at approximately 5 kHz for this design as the current ripple factor, ΔI_{RIPPLE} , was chosen at the onset of the design process to be 40%, which is large enough to force DCM operation and result in relatively high inductor ripple current. The required capacitor on I_{COMP} , $C_{\text{I COMP}}$, for this is determined using the transconductance gain, g_{mi} , of the internal current amplifier:

$$C_{\text{I COMP}} = \frac{g_{\text{mi}} \times M_1}{K_1 2\pi f_{\text{I AVG}}} \quad (100)$$

$$C_{\text{I COMP}} = \frac{0.95 \text{ mS} \times 0.538}{7 \times 2 \times \pi \times 3 \text{ kHz}} = 2330 \text{ pF} \quad (101)$$

A standard value 2700-pF capacitor for C_{ICOMP} results in a current averaging pole frequency of 4.314 kHz.

$$f_{I_{AVG}} = \frac{g_{mi} \times M_1}{K_1 \times 2 \times \pi \times 2700 \text{ pF}} = 4.314 \text{ kHz} \tag{102}$$

The transfer function of the current loop can be plotted:

$$G_{CL}(f) = \frac{K_1 2.5 R_{SENSE} V_{OUT}}{K_{FQ} M_1 M_2 L_{BST}} \times \frac{1}{s(f) + \frac{s(f)^2 K_1 C_{ICOMP}}{g_{mi} \times M_1}} \tag{103}$$

$$G_{CLdB}(f) = 20 \log(|G_{CL}(f)|) \tag{104}$$

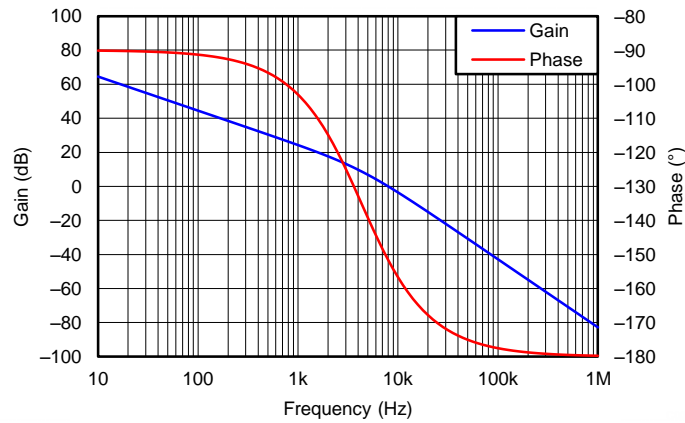

Figure 33. Bode Plot of the Current Averaging Circuit

UCC28180

SLUSBQ5A –NOVEMBER 2013–REVISED NOVEMBER 2013

www.ti.com

The voltage transfer function, $G_{VL(f)}$ contains the product of the voltage feedback gain, G_{FB} , and the gain from the pulse width modulator to the power stage, G_{PWM_PS} , which includes the pulse width modulator to power stage pole, f_{PWM_PS} . The plotted result is shown in [Figure 33](#).

$$G_{FB} = \frac{R_{FB2}}{R_{FB1} + R_{FB2}}$$

$$G_{FB} = \frac{13k\Omega}{1M\Omega + 13k\Omega} = 0.013 \quad (105)$$

$$f_{PWM_PS} = \frac{1}{2\pi \frac{K_1 2.5 R_{SENSE} V_{OUT}^3 C_{OUT}}{K_{FQ} M_1 M_2 V_{IN(nom)}^2}}$$

$$f_{PWM_PS} = \frac{1}{2\pi \frac{7 \times 2.5 \times 0.032\Omega \times 390V^3 \times 270\mu F}{8.475\mu s \times 0.539 \times 1.392 \frac{V}{\mu s} \times 115V^2}} = 1.479Hz \quad (106)$$

$$G_{PWM_PS}(f) = \frac{\frac{M_3 V_{OUT}}{M_1 M_2 \times 1V}}{1 + \frac{s(f)}{2\pi f_{PWM_PS}}}$$

$$(107)$$

$$G_{VL}(f) = G_{FB} G_{PWM_PS}(f)$$

$$G_{VLdB}(f) = 20\log(|G_{VL}(f)|) \quad (108)$$

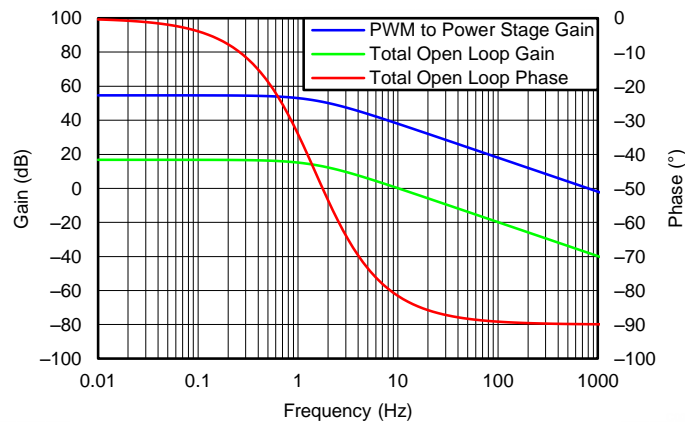

Figure 34. Bode Plot of the Open Voltage Loop without Error Amplifier

The voltage error amplifier is compensated with a zero, f_{ZERO} , at the f_{PWM_PS} pole and a pole, f_{POLE} , placed at 20 Hz to reject high frequency noise and roll off the gain amplitude. The overall voltage loop crossover, f_V , is desired to be at 10 Hz. The compensation components of the voltage error amplifier are selected accordingly.

$$f_{ZERO} = \frac{1}{2\pi R_{VCOMP} C_{VCOMP}} \quad (109)$$

$$f_{POLE} = \frac{1}{2\pi \frac{R_{VCOMP} C_{VCOMP} C_{VCOMP_P}}{C_{VCOMP} + C_{VCOMP_P}}} \quad (110)$$

$$G_{EA}(f) = g_{mv} \left[\frac{1 + s(f) R_{VCOMP} C_{VCOMP}}{(C_{VCOMP} + C_{VCOMP_P}) s(f) \left[1 + s(f) \left(\frac{R_{VCOMP} C_{VCOMP} C_{VCOMP_P}}{C_{VCOMP} + C_{VCOMP_P}} \right) \right]} \right] \quad (111)$$

From Figure 34, the gain of the voltage transfer function at 10 Hz is approximately 0.081 dB. Estimating that the parallel capacitor, C_{VCOMP_P} , is much smaller than the series capacitor, C_{VCOMP} , the unity gain will be at f_V , and the zero will be at f_{PWM_PS} , the series compensation capacitor is determined:

$$f_V = 10\text{Hz} \quad (112)$$

$$C_{VCOMP} = \frac{g_{mv} \frac{f_V}{f_{PWM_PS}}}{10^{\frac{0 - G_{VLdB}(f)}{20}} \times 2\pi f_V} \quad (113)$$

$$C_{VCOMP} = \frac{56\mu\text{s} \times \frac{10\text{Hz}}{1.479\text{Hz}}}{10^{\frac{0 - 0.081\text{dB}}{20}} \times 2 \times \pi \times 10\text{Hz}} = 6.08\mu\text{F} \quad (114)$$

The capacitor for VCOMP must have a voltage rating that is greater than the absolute maximum voltage rating of the VCOMP pin, which is 7 V. The readily available standard value capacitor that is rated for at least 10 V in the package size that would fit the application was 4.7 μF and this is the value used for C_{VCOMP} in this design example.

R_{VCOMP} is calculated using the actual C_{VCOMP} capacitor value.

$$C_{VCOMP} = 4.7\mu\text{F} \quad (115)$$

$$R_{VCOMP} = \frac{1}{2\pi f_{ZERO} C_{VCOMP}} \quad (116)$$

$$R_{VCOMP} = \frac{1}{2 \times \pi \times 1.479\text{Hz} \times 4.7\mu\text{F}} = 22.89\text{k}\Omega \quad (117)$$

A 22.6-k Ω resistor is used for R_{VCOMP} .

$$C_{VCOMP_P} = \frac{C_{VCOMP}}{2\pi f_{POLE} R_{VCOMP} C_{VCOMP} - 1} \quad (118)$$

$$C_{VCOMP_P} = \frac{4.7\mu\text{F}}{2 \times \pi \times 20\text{Hz} \times 22.6\text{k}\Omega \times 4.7\mu\text{F} - 1} = 0.381\mu\text{F} \quad (119)$$

A 0.47- μF capacitor is used for C_{VCOMP_P} .

UCC28180

SLUSBQ5A –NOVEMBER 2013–REVISED NOVEMBER 2013

www.ti.com

The total closed loop transfer function, G_{VL_total} , contains the combined stages and is plotted in [Figure 35](#).

$$G_{VL_total}(f) = G_{FB}(f)G_{PWM_PS}(f)G_{EA}(f) \quad (120)$$

$$G_{VL_totaldB}(f) = 20\log\left(\left|G_{VL_total}(f)\right|\right) \quad (121)$$

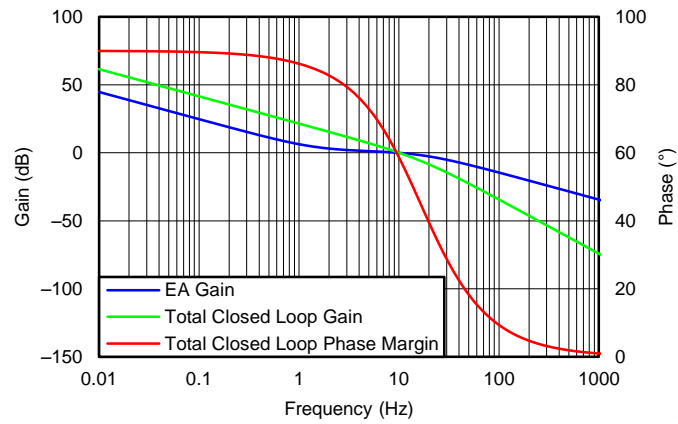

Figure 35. Closed Loop Voltage Bode Plot

Layout Guidelines

Layout Guidelines

As with all PWM controllers, the effectiveness of the filter capacitors on the signal pins depends upon the integrity of the ground return. Separating the high di/dt induced noise on the power ground from the low current quiet signal ground is required for adequate noise immunity. Even with a signal layer PCB design, the pin out of the UCC28180 is ideally suited to minimize noise on the small signal traces. As shown in [Figure 36](#), the capacitors on VSENSE, VCOMP, ISENSE, ICOMP, and FREQ (if used) must be all be returned directly to the portion of the ground plane that is the quiet signal GND and not in high-current return path of the converter, shown as power GND. The trace from the FREQ pin to the frequency programming resistor should be as short as possible. It is recommended that the compensation components on ICOMP and VCOMP are located as close as possible to the UCC28180. Placement of these components should take precedence, paying close attention to keeping their traces away from high noise areas. The bypass capacitors on VCC must be located physically close the VCC and GND pins of the UCC28180 but should not be in the immediate path of the signal return.

Other layout considerations should include keeping the switch node as short as possible, with a wide trace to reduce induced ringing caused by parasitic inductance. Every effort should be made to avoid noise from the switch node from corrupting the small signal traces with adequate clearance and ground shielding. As some compromises must be made due to limitation of PCB layers or space constraints, traces that must be made long, such as the signal from the current sense resistor shown in [Figure 36](#), should be as wide as possible, avoid long narrow traces.

Table 2. Layout Component Description for [Figure 36](#)

LAYOUT COMPONENTS	
REFERENCE DESIGNATOR	FUNCTION
U1	Controller, UCC28180
Q1	Main switch
D2	Boost diode
R5	RGATE
R7	Pull-down resistor on GATE
D1	Turn-off diode on GATE
C11, C12	VCC bypass capacitors
C7	ICOMP compensation, C_{ICOMP}
R1, C6	Placeholders for additional ICOMP compensation, if needed
C8	ISENSE filter, C_{ISENSE}
R2	ISENSE inrush current limiting resistor, R_{ISENSE}
R3	Frequency programming resistor, R_{FREQ}
C9	Placeholder for FREQ filter, if needed
R6, C13, C14	VCOMP compensation components, R_{VCOMP} , C_{VCOMP_P} , C_{VCOMP}
C15	VSENSE filter, C_{VSENSE}
R11, R12	R_{FB1} on VSENSE
R13	R_{FB2} on VSENSE

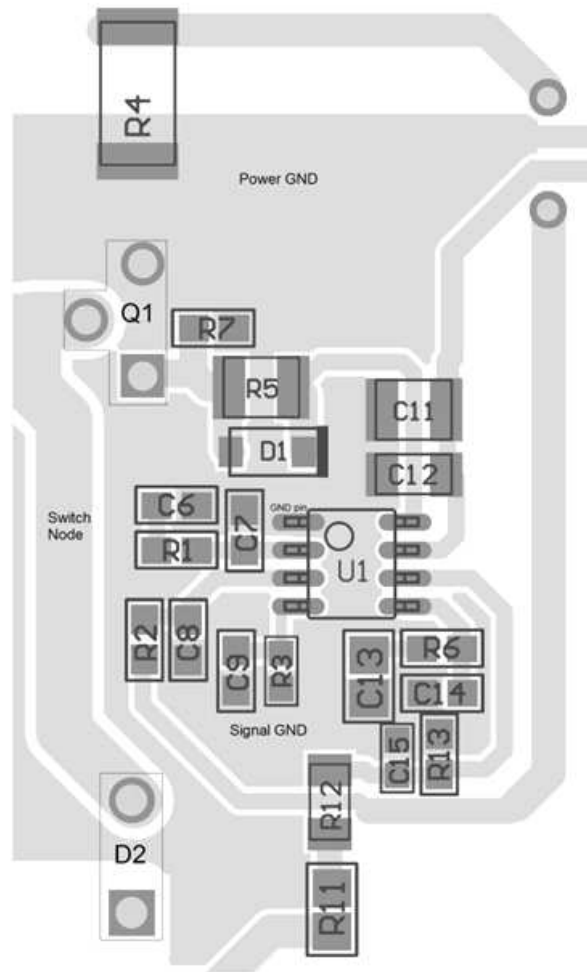

Figure 36. Recommended Layout for UCC28180

Additional References

References

These references, additional design tools, and links to additional references, including design software and models may be found on the web at <http://www.power.ti.com> under Technical Documents.

User Guide, *Using the UCC28180EVM-573, 360-W Power Factor Correction*, Texas Instruments Literature No. SLUUAT3

Design Spreadsheet, *UCC28180 Design Calculator*, Texas Instruments Literature No. SLUC506

REVISION HISTORY

Changes from Original (November 2013) to Revision A	Page
• Added Features bullet, "Reduced Current Sense Threshold"	1
• Changed marketing status from Product Preview to Production Data.	1
• Added Figure 8 through Figure 13.	8
• Changed Figure 31 through Figure 35.	21

PACKAGING INFORMATION

Orderable Device	Status (1)	Package Type	Package Drawing	Pins	Package Qty	Eco Plan (2)	Lead/Ball Finish (6)	MSL Peak Temp (3)	Op Temp (°C)	Device Marking (4/5)	Samples
UCC28180D	ACTIVE	SOIC	D	8	75	Green (RoHS & no Sb/Br)	CU NIPDAU	Level-1-260C-UNLIM		U28180	Samples
UCC28180DR	ACTIVE	SOIC	D	8	2500	Green (RoHS & no Sb/Br)	CU NIPDAU	Level-1-260C-UNLIM		U28180	Samples

(1) The marketing status values are defined as follows:

ACTIVE: Product device recommended for new designs.

LIFEBUY: TI has announced that the device will be discontinued, and a lifetime-buy period is in effect.

NRND: Not recommended for new designs. Device is in production to support existing customers, but TI does not recommend using this part in a new design.

PREVIEW: Device has been announced but is not in production. Samples may or may not be available.

OBSOLETE: TI has discontinued the production of the device.

(2) Eco Plan - The planned eco-friendly classification: Pb-Free (RoHS), Pb-Free (RoHS Exempt), or Green (RoHS & no Sb/Br) - please check <http://www.ti.com/productcontent> for the latest availability information and additional product content details.

TBD: The Pb-Free/Green conversion plan has not been defined.

Pb-Free (RoHS): TI's terms "Lead-Free" or "Pb-Free" mean semiconductor products that are compatible with the current RoHS requirements for all 6 substances, including the requirement that lead not exceed 0.1% by weight in homogeneous materials. Where designed to be soldered at high temperatures, TI Pb-Free products are suitable for use in specified lead-free processes.

Pb-Free (RoHS Exempt): This component has a RoHS exemption for either 1) lead-based flip-chip solder bumps used between the die and package, or 2) lead-based die adhesive used between the die and leadframe. The component is otherwise considered Pb-Free (RoHS compatible) as defined above.

Green (RoHS & no Sb/Br): TI defines "Green" to mean Pb-Free (RoHS compatible), and free of Bromine (Br) and Antimony (Sb) based flame retardants (Br or Sb do not exceed 0.1% by weight in homogeneous material)

(3) MSL, Peak Temp. - The Moisture Sensitivity Level rating according to the JEDEC industry standard classifications, and peak solder temperature.

(4) There may be additional marking, which relates to the logo, the lot trace code information, or the environmental category on the device.

(5) Multiple Device Markings will be inside parentheses. Only one Device Marking contained in parentheses and separated by a "~" will appear on a device. If a line is indented then it is a continuation of the previous line and the two combined represent the entire Device Marking for that device.

(6) Lead/Ball Finish - Orderable Devices may have multiple material finish options. Finish options are separated by a vertical ruled line. Lead/Ball Finish values may wrap to two lines if the finish value exceeds the maximum column width.

Important Information and Disclaimer: The information provided on this page represents TI's knowledge and belief as of the date that it is provided. TI bases its knowledge and belief on information provided by third parties, and makes no representation or warranty as to the accuracy of such information. Efforts are underway to better integrate information from third parties. TI has taken and continues to take reasonable steps to provide representative and accurate information but may not have conducted destructive testing or chemical analysis on incoming materials and chemicals. TI and TI suppliers consider certain information to be proprietary, and thus CAS numbers and other limited information may not be available for release.

In no event shall TI's liability arising out of such information exceed the total purchase price of the TI part(s) at issue in this document sold by TI to Customer on an annual basis.

TAPE AND REEL INFORMATION



QUADRANT ASSIGNMENTS FOR PIN 1 ORIENTATION IN TAPE

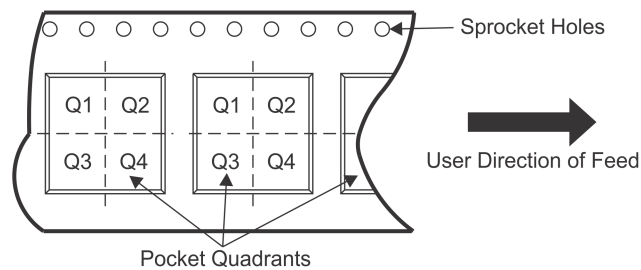

*All dimensions are nominal

Device	Package Type	Package Drawing	Pins	SPQ	Reel Diameter (mm)	Reel Width W1 (mm)	A0 (mm)	B0 (mm)	K0 (mm)	P1 (mm)	W (mm)	Pin1 Quadrant
UCC28180DR	SOIC	D	8	2500	330.0	12.4	6.4	5.2	2.1	8.0	12.0	Q1

TAPE AND REEL BOX DIMENSIONS

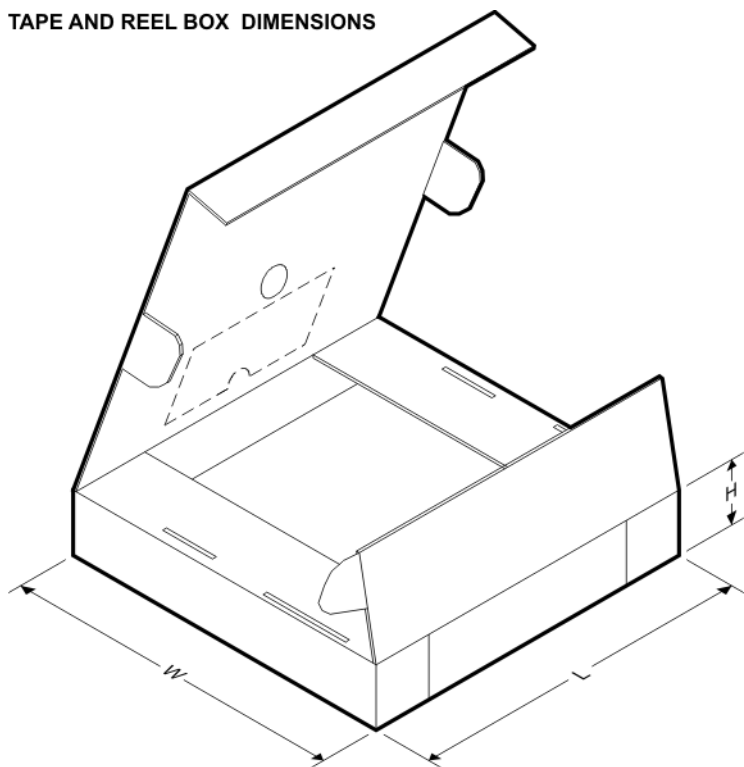

*All dimensions are nominal

Device	Package Type	Package Drawing	Pins	SPQ	Length (mm)	Width (mm)	Height (mm)
UCC28180DR	SOIC	D	8	2500	340.5	338.1	20.6

D (R-PDSO-G8)

PLASTIC SMALL OUTLINE

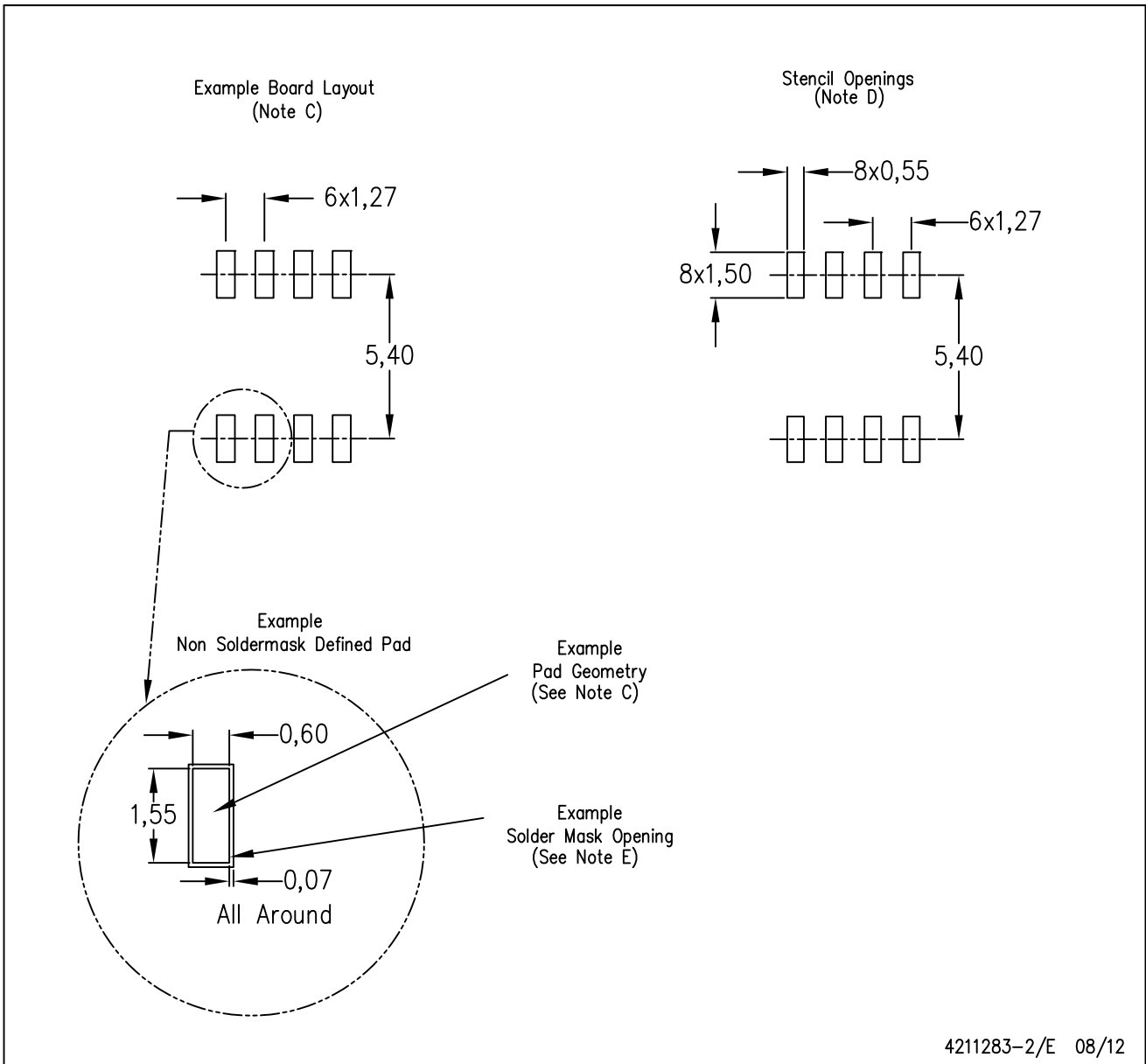

- NOTES:
- All linear dimensions are in millimeters.
 - This drawing is subject to change without notice.
 - Publication IPC-7351 is recommended for alternate designs.
 - Laser cutting apertures with trapezoidal walls and also rounding corners will offer better paste release. Customers should contact their board assembly site for stencil design recommendations. Refer to IPC-7525 for other stencil recommendations.
 - Customers should contact their board fabrication site for solder mask tolerances between and around signal pads.

IMPORTANT NOTICE

Texas Instruments Incorporated and its subsidiaries (TI) reserve the right to make corrections, enhancements, improvements and other changes to its semiconductor products and services per JESD46, latest issue, and to discontinue any product or service per JESD48, latest issue. Buyers should obtain the latest relevant information before placing orders and should verify that such information is current and complete. All semiconductor products (also referred to herein as "components") are sold subject to TI's terms and conditions of sale supplied at the time of order acknowledgment.

TI warrants performance of its components to the specifications applicable at the time of sale, in accordance with the warranty in TI's terms and conditions of sale of semiconductor products. Testing and other quality control techniques are used to the extent TI deems necessary to support this warranty. Except where mandated by applicable law, testing of all parameters of each component is not necessarily performed.

TI assumes no liability for applications assistance or the design of Buyers' products. Buyers are responsible for their products and applications using TI components. To minimize the risks associated with Buyers' products and applications, Buyers should provide adequate design and operating safeguards.

TI does not warrant or represent that any license, either express or implied, is granted under any patent right, copyright, mask work right, or other intellectual property right relating to any combination, machine, or process in which TI components or services are used. Information published by TI regarding third-party products or services does not constitute a license to use such products or services or a warranty or endorsement thereof. Use of such information may require a license from a third party under the patents or other intellectual property of the third party, or a license from TI under the patents or other intellectual property of TI.

Reproduction of significant portions of TI information in TI data books or data sheets is permissible only if reproduction is without alteration and is accompanied by all associated warranties, conditions, limitations, and notices. TI is not responsible or liable for such altered documentation. Information of third parties may be subject to additional restrictions.

Resale of TI components or services with statements different from or beyond the parameters stated by TI for that component or service voids all express and any implied warranties for the associated TI component or service and is an unfair and deceptive business practice. TI is not responsible or liable for any such statements.

Buyer acknowledges and agrees that it is solely responsible for compliance with all legal, regulatory and safety-related requirements concerning its products, and any use of TI components in its applications, notwithstanding any applications-related information or support that may be provided by TI. Buyer represents and agrees that it has all the necessary expertise to create and implement safeguards which anticipate dangerous consequences of failures, monitor failures and their consequences, lessen the likelihood of failures that might cause harm and take appropriate remedial actions. Buyer will fully indemnify TI and its representatives against any damages arising out of the use of any TI components in safety-critical applications.

In some cases, TI components may be promoted specifically to facilitate safety-related applications. With such components, TI's goal is to help enable customers to design and create their own end-product solutions that meet applicable functional safety standards and requirements. Nonetheless, such components are subject to these terms.

No TI components are authorized for use in FDA Class III (or similar life-critical medical equipment) unless authorized officers of the parties have executed a special agreement specifically governing such use.

Only those TI components which TI has specifically designated as military grade or "enhanced plastic" are designed and intended for use in military/aerospace applications or environments. Buyer acknowledges and agrees that any military or aerospace use of TI components which have **not** been so designated is solely at the Buyer's risk, and that Buyer is solely responsible for compliance with all legal and regulatory requirements in connection with such use.

TI has specifically designated certain components as meeting ISO/TS16949 requirements, mainly for automotive use. In any case of use of non-designated products, TI will not be responsible for any failure to meet ISO/TS16949.

Products

Audio	www.ti.com/audio
Amplifiers	amplifier.ti.com
Data Converters	dataconverter.ti.com
DLP® Products	www.dlp.com
DSP	dsp.ti.com
Clocks and Timers	www.ti.com/clocks
Interface	interface.ti.com
Logic	logic.ti.com
Power Mgmt	power.ti.com
Microcontrollers	microcontroller.ti.com
RFID	www.ti-rfid.com
OMAP Applications Processors	www.ti.com/omap
Wireless Connectivity	www.ti.com/wirelessconnectivity

Applications

Automotive and Transportation	www.ti.com/automotive
Communications and Telecom	www.ti.com/communications
Computers and Peripherals	www.ti.com/computers
Consumer Electronics	www.ti.com/consumer-apps
Energy and Lighting	www.ti.com/energy
Industrial	www.ti.com/industrial
Medical	www.ti.com/medical
Security	www.ti.com/security
Space, Avionics and Defense	www.ti.com/space-avionics-defense
Video and Imaging	www.ti.com/video

TI E2E Community

e2e.ti.com